

Final Subdivision Plat of

Block 25, Discovery Office Park/Superior Town Center Replat No. 2

Being a Replat of Outlot G of Lot 1, Block 25 of Discovery Office Park/Superior Town Center Replat, and Superlot A, Block 25 of Discovery Office Park/Superior Town Center Replat No. 3, Situate in the West Half of Section 19, Township 1 South, Range 69 West of the 6th P.M., Town of Superior, County of Boulder, State of Colorado

DATE:	3/12/2019
FILE NAME:	20160677B-SUB
SCALE:	N/A
DRAWN BY:	CSK
CHECKED BY:	PG

KING SURVEYORS
650 E. Garden Drive | Windsor, Colorado 80550
phone: (970) 686-5011 | email: contact@Kingsurveyors.com



REVISIONS:	DATE:	
CORR CHECKED	CSK	1/21/19
REVISE PER COMMENTS	CSK	2/27/19
REVISE PER COMMENTS	CSK	3/26/19

Block 25, DISCOVERY OFFICE PARK/SUPERIOR TOWN CENTER REPLAT NO. 2 FOR CIVIL RESOURCES, LLC P.O. BOX 680, FREDERICK, CO 80530

PROJECT #: 20160677-B

CERTIFICATE OF DEDICATION AND OWNERSHIP

Know all men by these presents that the RC Superior, LLC and Town of Superior, being the Owner(s) of certain lands in Boulder County, Colorado, described as follows:

Outlot G of the Lot 1, Block 25 of Discovery Office Park/Superior Town Center Replat recorded August 18, 2016 as Reception No. 3537943 of the Records of Boulder County Recorders, and Superlot A, Block 25 of Discovery Office Park/Superior Town Center Replat No. 3 recorded January 4, 2018 as Reception No. 3634334 of the Records of Boulder County Recorders, situate in the West Half (W/2) of Section Nineteen (19), Township One South (T.1S.), Range Sixty-nine West (R.69W.), Sixth Principal Meridian (6th P.M.), Town of Superior, County of Boulder, State of Colorado.

Said parcels in total contain 5.388 acres, more or less (±).

Have by these presents laid out, platted and subdivided the same into lots, blocks and outlots, as shown on this plat, under the name and style of a Subdivision Plat of Block 25, DISCOVERY OFFICE PARK/SUPERIOR TOWN CENTER REPLAT NO. 2 and do hereby dedicate to the public the easements for purposes shown herein and summarized in the Ownership and Maintenance Table below.

Executed this 14 day of March, 2019

OWNER:

RC SUPERIOR, LLC, a Delaware limited liability company
By: Superior Town Center ASL VII Holdings, LLC, a Delaware limited liability company, its sole Member
By: Avanti Strategic Land Investors VII, L.L.L.P., a Delaware limited liability limited partnership, its sole Member
By: Avanti Properties Group II, L.L.L.P., a Delaware limited liability limited partnership, its Managing General Partner
By: Avanti Management Corporation, a Florida Corporation, its sole General Partner

By: Marvin Shapiro Its: President
Name: Marvin Shapiro

NOTARIAL CERTIFICATE

STATE OF FLORIDA)
 ss

COUNTY OF ORANGE)

The foregoing instrument was acknowledged before me this 14 day of March, 2019, by Marvin Shapiro as President of Avanti Management Corporation, a Florida Corporation, sole general partner of Avanti Strategic Land Investors VII, L.L.L.P., a Delaware limited liability limited partnership, managing general partner of Avanti Properties Group II, L.L.L.P., a Delaware limited liability limited partnership, sole member of Superior Town Center ASL VII Holdings, LLC, a Delaware limited liability company, sole member of RC Superior, LLC, a Delaware limited liability company.

WITNESS my hand and official seal. (SEAL)

My commission expires 1/22/22
Shannon Kaitland Staunton
Notary Public



OWNER'S ESTOPPEL CERTIFICATE

We, RC Superior, LLC, a Delaware limited liability company, the owner of the property include in this subdivision, certifies that this final plat, FDP 3-2, Superior Town Center PD Amendment #3, and the subdivision improvement agreement to be executed in connection herewith, if required, embody the entire agreement between the owner of said property and the Town with regard to the subdivision of said property, and that the owner is not relying upon any other representations, warranties, understandings or agreements in connection with any matter encompassed by this plat or the subdivision improvement agreement if required, except as set forth herein or in said subdivision improvement agreement.

RC SUPERIOR, LLC, a Delaware limited liability company
By: Superior Town Center ASL VII Holdings, LLC, a Delaware limited liability company, its sole Member
By: Avanti Strategic Land Investors VII, L.L.L.P., a Delaware limited liability limited partnership, its sole Member
By: Avanti Properties Group II, L.L.L.P., a Delaware limited liability limited partnership, its Managing General Partner
By: Avanti Management Corporation, a Florida corporation, its sole General Partner

By: Marvin Shapiro Its: President
Name: Marvin Shapiro

LENDER'S CONSENT AND SUBORDINATION

The Undersigned, beneficiary under a certain deed of trust encumbering the Property, hereby expressly consents to and joins in the execution and recording of this plat, dedication and easements shown hereon and makes the deed of trust subordinate hereto. The undersigned represents that he or she has full power and authority to execute this lender's consent and subordination on behalf of the undersigned.

Wells Fargo Bank
By: Valerie A. Girrens
Name: Valerie A. Girrens
Title: Vice President

Acknowledgement

State of Florida

County of Hillsborough

Acknowledged before me this 19th day of March 2019 by Valerie A. Girrens as VP of Wells Fargo Bank

Witness my hand and official seal

My commission expires 1/11/2023
Sandra Garcia
Notary Public

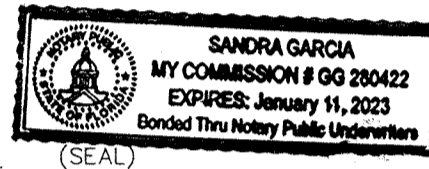

COUNTY CLERK AND RECORDER CERTIFICATE

This plat was filed for record in the office of the County Clerk and Recorder of Boulder County at 1:12 PM on the 25 day of March, 2019, in Book _____, Page _____

Map _____, Reception No. 03703642, Fees: \$43.00

County Clerk and Recorder Molly Fitzpatrick

By: Molly Fitzpatrick
Deputy

STATE OF COLORADO)
 ss
COUNTY OF BOULDER)

TOWN BOARD CERTIFICATE

Approved by the Town Board of the Town of Superior, State of Colorado.

Witness my hand the corporate seal of the Town of Superior this 26th day of March, 2019

Attest: Phyllis L. Gordon Town Clerk
Clint Folsom Mayor



PLANNING COMMISSION CERTIFICATE

Recommended approval this 18th day of December, 2018, by the Town of Superior Planning Commission, Resolution No. PC 11-19 Series 2018.

TOWN CLERK CERTIFICATE

I hereby certify that this instrument as approved by the Board of Trustees by [Resolution/Guidance] No. R-2 Series 2019 on this 14th day of January, 2019, and was filed in my office on the 21st day of March, 2019, in Block A-2.

By: Phyllis L. Gordon
Town Clerk



VACATION NOTE

Know all men by these presents that we the undersigned, being the owner(s) of the land described herein, and as shown on the attached map do hereby vacate all lot lines of the above described parcel of land.

VACATION STATEMENT

Know all men by these presents: that we, the Town of Superior, being owner(s) of the Easements being a portion of Outlot G and Superlot A of the Lot 1, Block 25 of Discovery Office Park/Superior Town Center Replat recorded August 18, 2016 as Reception No. 3537943 of the Records of Boulder County Recorders, situate in the West Half of Section 19, Township One South, Range Sixty-nine West, of the 6th P.M., Town of Superior, County of Boulder, State of Colorado, do hereby vacate the easements labeled "VACATED BY THIS PLAT AS SHOWN HATCHED" and rededicate said Easements as shown hereon.

- Utility Easement
- Utility and Emergency Access Easement
- Site Triangle Easement

In witness whereof, and being the owner(s) of said Easements. We have set our hands and seals this 21st day of March, 2019.

By: Clint Folsom As: Mayor

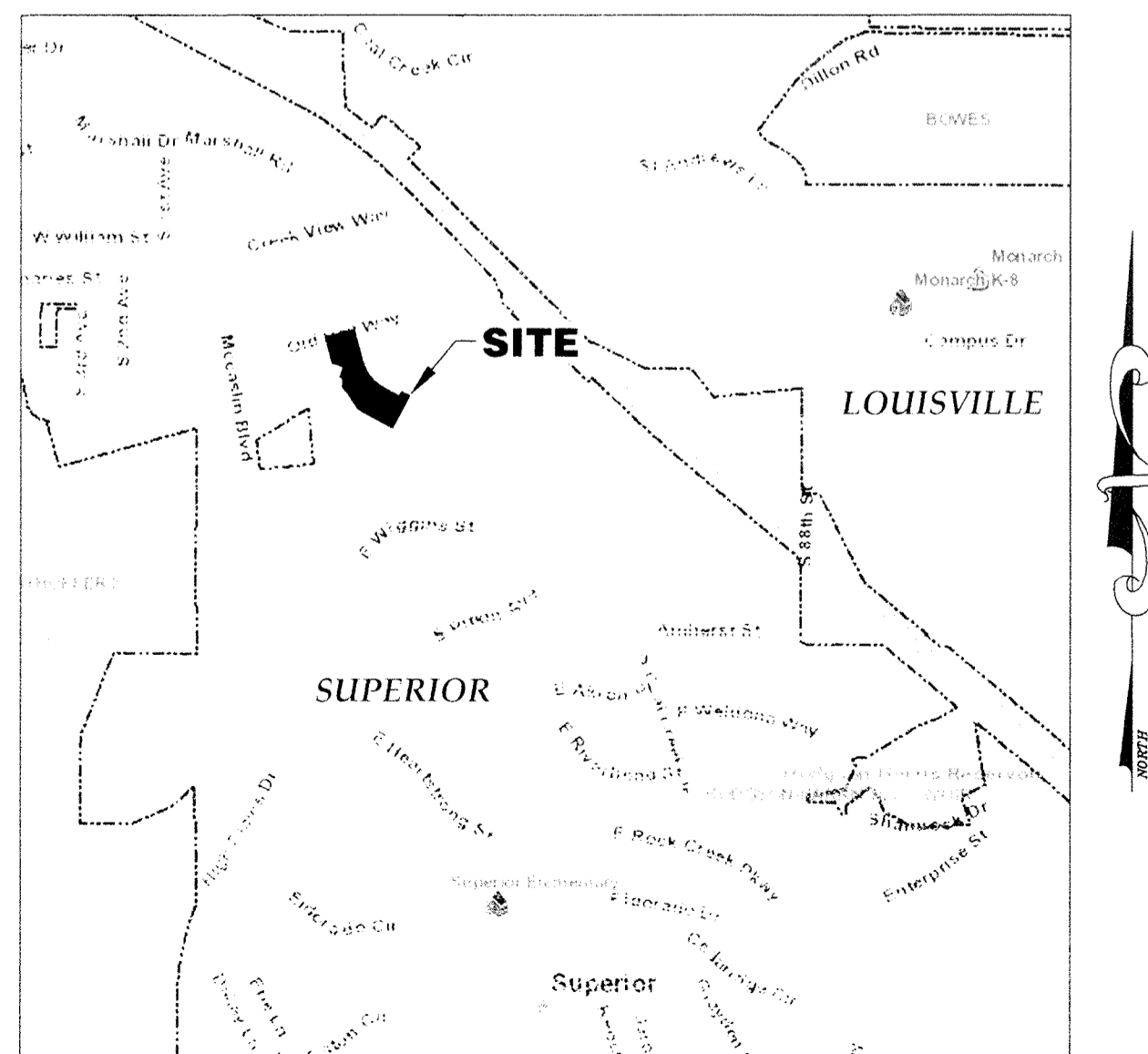

VICINITY MAP (NOT TO SCALE)

CURVE TABLE					
CURVE	LENGTH	RADIUS	DELTA	CHORD	CH BEARING
C1	308.94'	380.00'	46°34'52"	300.50'	S38°21'02"E
C2	81.15'	168.00'	27°40'33"	80.36'	N47°48'39"W
C3	43.03'	229.00'	10°45'54"	42.96'	N39°21'19"W
C4	52.11'	380.00'	7°51'28"	52.07'	N74°48'25"W
C5	335.77'	413.00'	46°34'52"	326.60'	S38°21'02"E
C6	2.29'	413.00'	0°19'04"	2.29'	S151°3'08"E
C7	27.02'	413.00'	3°44'57"	27.02'	S171°5'08"E
C8	14.00'	413.00'	1°56'33"	14.00'	S20°05'53"E
C9	27.05'	413.00'	3°45'10"	27.05'	S22°56'45"E
C10	25.00'	413.00'	3°28'08"	25.00'	S26°33'24"E
C11	27.07'	413.00'	3°45'18"	27.06'	S30°10'07"E
C12	31.99'	413.00'	4°26'18"	31.98'	S34°15'55"E
C13	27.13'	413.00'	3°45'51"	27.13'	S38°21'59"E
C14	25.02'	413.00'	3°28'15"	25.01'	S41°59'02"E
C15	25.01'	413.00'	3°28'12"	25.01'	S45°27'15"E
C16	27.11'	413.00'	3°45'42"	27.11'	S49°04'12"E
C17	14.51'	413.00'	2°00'46"	14.51'	S51°57'26"E
C18	22.17'	413.00'	3°04'35"	22.17'	S54°30'06"E
C19	20.06'	413.00'	2°46'57"	20.05'	S57°25'51"E
C20	20.01'	413.00'	2°46'33"	20.01'	S60°12'36"E
C21	0.31'	413.00'	0°02'36"	0.31'	S61°37'10"E
C22	2.20'	168.00'	0°45'04"	2.20'	S34°20'54"E
C23	51.97'	168.00'	17°43'22"	51.76'	S43°35'07"E
C24	26.98'	168.00'	9°12'07"	26.95'	S57°02'52"E
C25	74.75'	154.75'	27°40'33"	74.03'	S47°48'39"E

CURVE TABLE					
CURVE	LENGTH	RADIUS	DELTA	CHORD	CH BEARING
C26	7.81'	154.75'	2°53'36"	7.81'	S35°25'10"E
C27	40.13'	154.75'	14°51'31"	40.02'	S44°17'43"E
C28	25.84'	154.75'	9°33'58"	25.81'	S56°30'28"E
C29	0.97'	154.75'	0°21'29"	0.97'	S61°28'11"E
C30	59.78'	123.75'	27°40'33"	59.20'	S47°48'39"E
C31	2.97'	229.00'	0°44'40"	2.97'	N34°20'42"W
C32	40.05'	229.00'	10°01'14"	40.00'	N39°43'39"W
C33	58.42'	74.00'	45°14'05"	56.92'	N56°35'24"W
C34	43.99'	74.00'	34°03'34"	43.34'	N62°10'40"W
C35	14.43'	74.00'	11°10'31"	14.41'	N39°33'37"W
C36	81.73'	105.00'	44°35'51"	79.68'	N56°16'17"W
C37	7.08'	105.00'	3°51'51"	7.08'	N76°38'18"W
C38	25.13'	105.00'	13°42'51"	25.07'	N67°50'57"W
C39	25.40'	105.00'	13°51'44"	25.34'	N54°03'39"W
C40	24.11'	105.00'	13°09'25"	24.06'	N40°33'04"W
C41	23.55'	15.00'	89°57'57"	21.21'	N16°39'30"W
C42	25.61'	123.75'	11°51'28"	25.57'	S39°54'06"E
C43	34.16'	123.75'	15°49'05"	34.06'	S53°44'23"E
C44	0.50'	8.00'	3°35'00"	0.50'	S76°43'54"W
C45	12.07'	8.00'	86°25'00"	10.95'	N58°16'06"W
C46	7.75'	10.00'	44°25'37"	7.56'	N52°43'35"E

LINE TABLE		
LINE	BEARING	LENGTH
L1	N78°32'43"W	22.26'
L2	N34°56'49"W	10.27'
L3	N15°03'36"W	9.00'
L4	S26°30'56"W	3.00'
L5	S04°46'19"W	11.99'
L6	S89°21'12"W	10.30'
L7	N70°38'59"W	7.23'
L8	N60°03'36"W	9.90'
L9	S69°59'39"W	12.04'
L10	S73°21'32"W	14.14'
L11	S73°19'28"W	14.13'
L12	S74°56'24"W	3.50'
L13	N74°56'24"E	1.00'

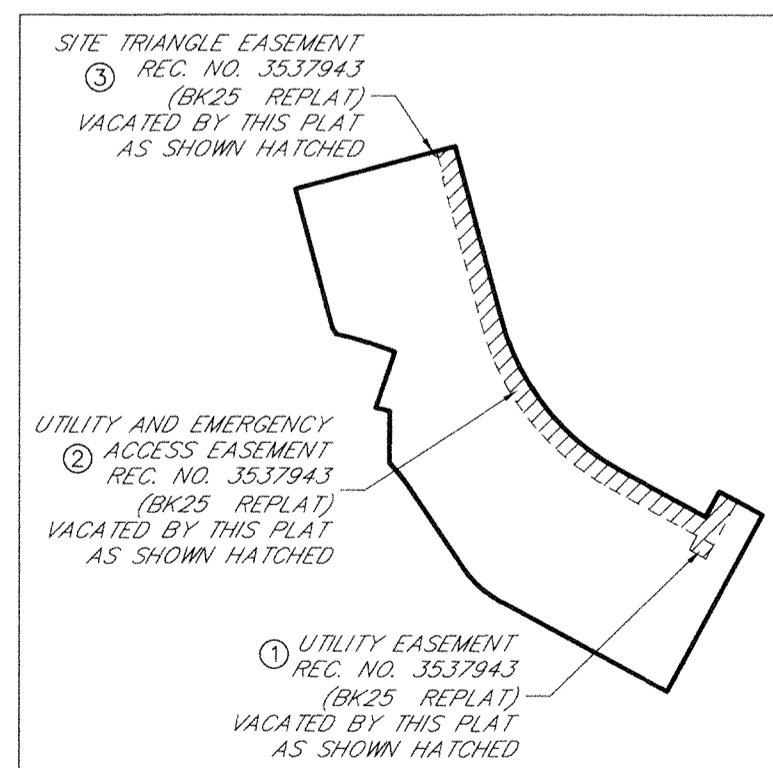

VACATION DETAIL SCALE: 1"=300'

LAND USE TABLE

PARCELS	ACREAGE	%
LOTS (75)	2.290 ACRES	43%
OUTLOTS (7)	3.098 ACRES	57%
TOTAL	5.388 ACRES	100%

SHEET LAYOUT

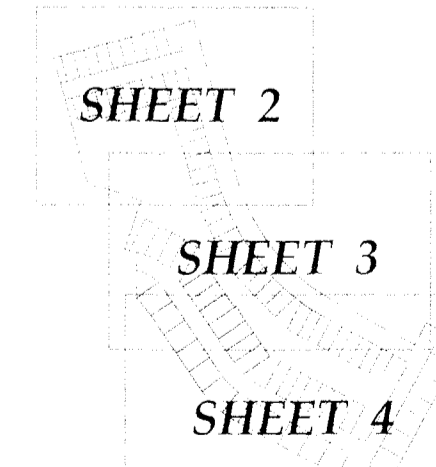

PARCEL	ACRES	USE	OWNER AND MAINTAINED BY
OUTLOT G	1.332 ACRES	UTILITY, PUBLIC ACCESS AND EMERGENCY ACCESS EASEMENT	STC METRO DISTRICT
OUTLOT H	0.031 ACRES	BLANKET PUBLIC ACCESS, DRAINAGE AND UTILITY EASEMENT	STC METRO DISTRICT
OUTLOT I	0.024 ACRES	BLANKET PUBLIC ACCESS AND UTILITY EASEMENT	STC METRO DISTRICT
OUTLOT J	0.024 ACRES	BLANKET PUBLIC ACCESS, DRAINAGE AND UTILITY EASEMENT	STC METRO DISTRICT
OUTLOT K	0.014 ACRES	BLANKET PUBLIC ACCESS AND UTILITY EASEMENT	STC METRO DISTRICT
OUTLOT L	1.644 ACRES	BLANKET PUBLIC ACCESS, DRAINAGE AND UTILITY EASEMENT	STC METRO DISTRICT
OUTLOT M	0.029 ACRES	BLANKET PUBLIC ACCESS, DRAINAGE AND UTILITY EASEMENT	STC METRO DISTRICT

Final Subdivision Plat of Block 25, Discovery Office Park/Superior Town Center Replat No. 2

Being a Replat of Outlot G of Lot 1, Block 25 of Discovery Office Park/Superior Town Center Replat, and Superlot A, Block 25 of Discovery Office Park/Superior Town Center Replat No. 3, Situate in the West Half of Section 19, Township 1 South, Range 69 West of the 6th P.M., Town of Superior, County of Boulder, State of Colorado

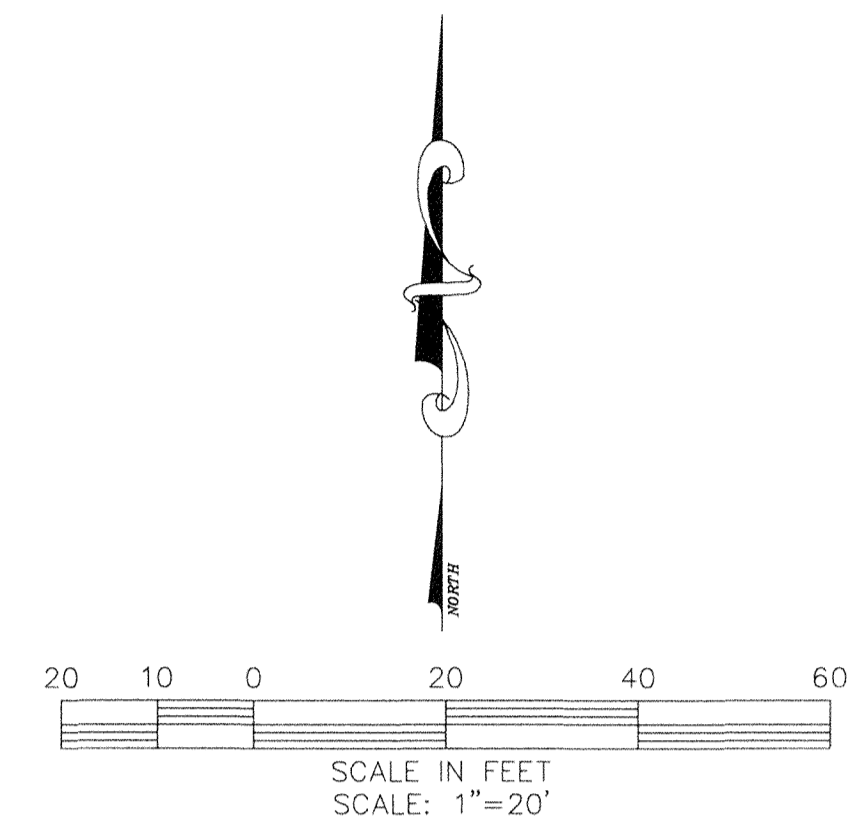
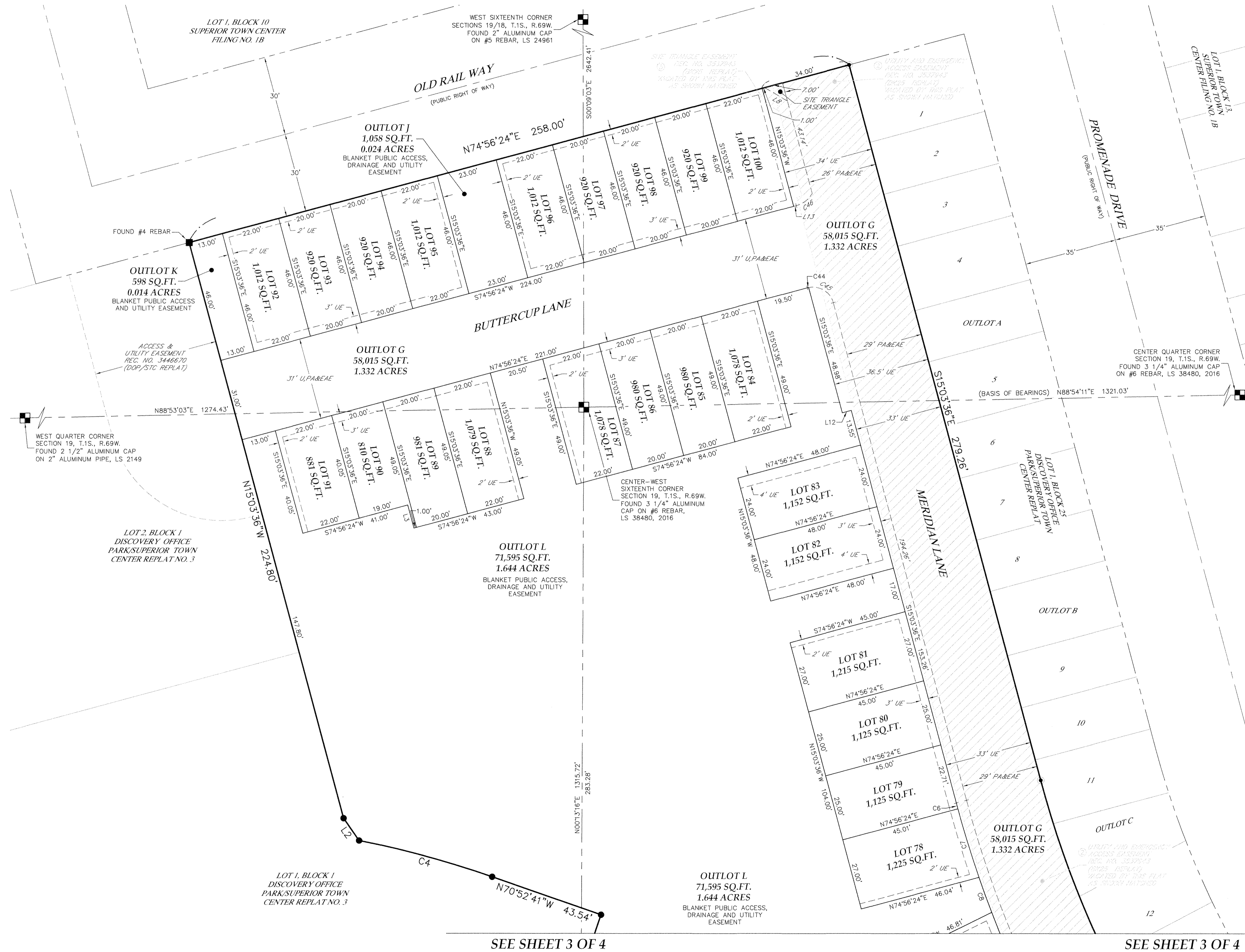

LEGEND

- EASEMENT LINE
- CENTERLINE
- SECTION LINE
- RIGHT-OF-WAY LINE
- PROPERTY LINE
- UE UTILITY EASEMENT
- PAE PUBLIC ACCESS EASEMENT
- PA&EAE PUBLIC ACCESS AND EMERGENCY ACCESS EASEMENT
- U,PA&EAE UTILITY, PUBLIC ACCESS AND EMERGENCY ACCESS EASEMENT
- FOUND ALIQUOT CORNER AS DESCRIBED
- FOUND MONUMENT AS DESCRIBED
- ◆ 2" WITNESS CORNER FOUND NAIL WITH BRASS CAP, LS 13485
- SET 24" OF #4 REBAR WITH A BLUE PLASTIC CAP STAMPED KS, LS 38209
- SET RIVET WITH A BRASS TAG STAMPED KS, LS 38209
- CALCULATED POSITION

** FOR LINE AND CURVE TABLE SEE SHEET 1 OF 4 **

SHEET LAYOUT

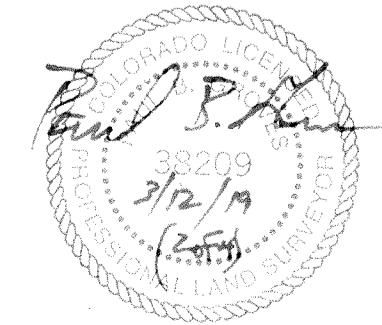
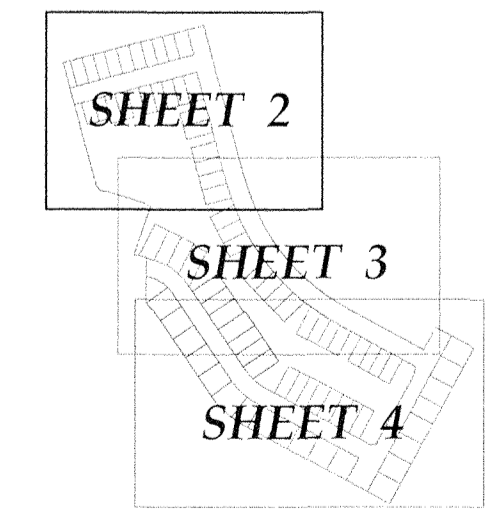

Paul B. Groves - On Behalf Of King Surveyors
Colorado Licensed Professional
Land Surveyor #38209

DATE:	3/7/2019
FILE NAME:	20160677B-SUB
SCALE:	1"=20'
DRAWN BY:	CSK
CHECKED BY:	PG

KING SURVEYORS
650 E. Garden Drive | Windsor, Colorado 80550
phone: (970) 686-5011 | email: contact@KingSurveyors.com



DATE:	1/21/19
CSK	1/21/19
REVISIONS:	CSK 2/19/19
CODG CHECKED	CSK 3/6/19
REVISE PER COMMENTS	
REVISE PER COMMENTS	

Block 25, DISCOVERY OFFICE
PARK/SUPERIOR TOWN CENTER REPLAT NO. 2
FOR
CIVIL RESOURCES, LLC
P.O. BOX 680, FREDERICK, CO 80530

PROJECT #
20160677-B

2

Final Subdivision Plat of Block 25, Discovery Office Park/Superior Town Center Replat No. 2

Being a Replat of Outlot G of Lot 1, Block 25 of Discovery Office Park/Superior Town Center Replat, and Superlot A, Block 25 of Discovery Office Park/Superior Town Center Replat No. 3, Situate in the West Half of Section 19, Township 1 South, Range 69 West of the 6th P.M., Town of Superior, County of Boulder, State of Colorado

SEE SHEET 2 OF 4

SEE SHEET 2 OF 4

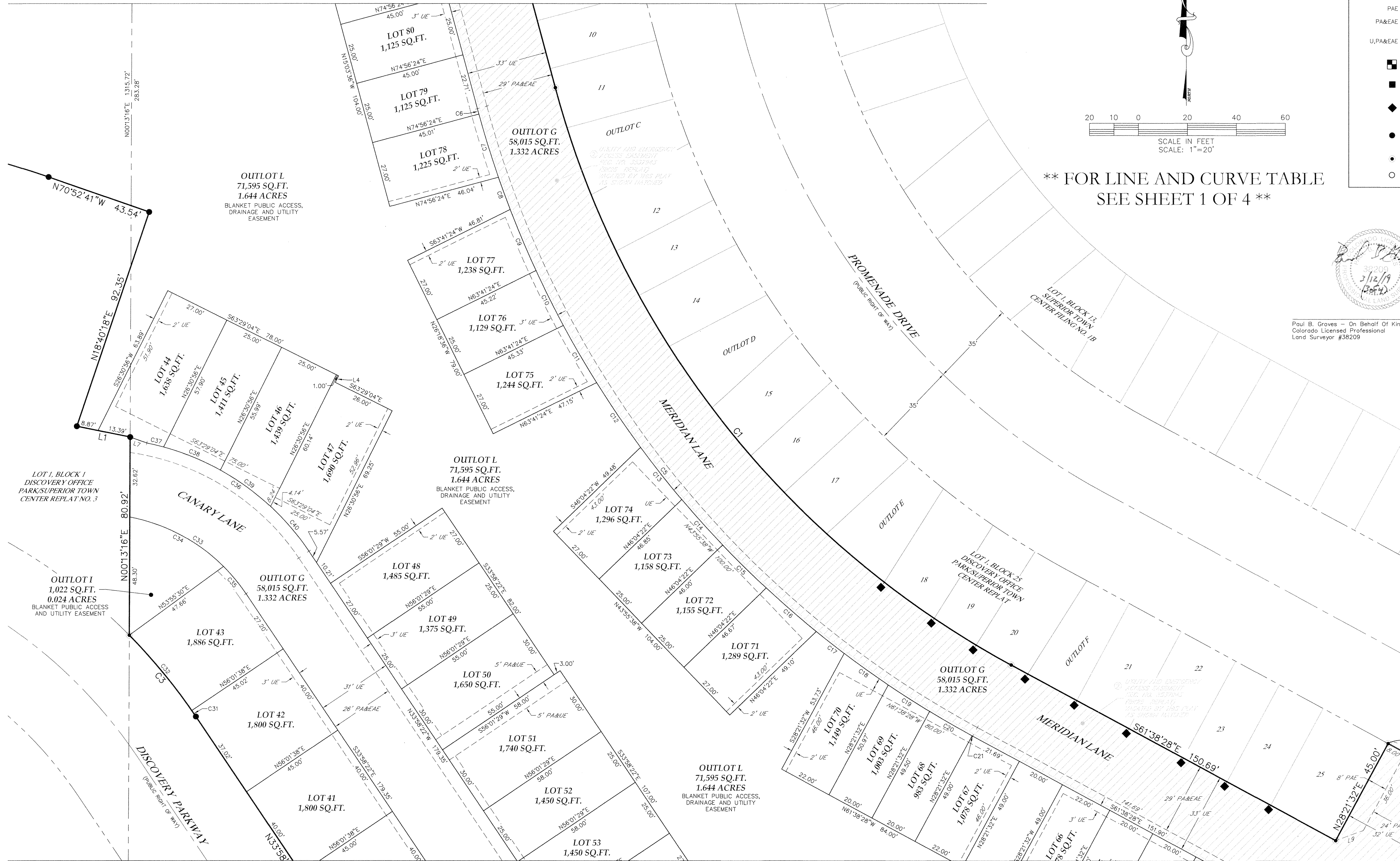

LEGEND

- EASEMENT LINE
- CENTERLINE
- SECTION LINE
- RIGHT-OF-WAY LINE
- PROPERTY LINE
- UE UTILITY EASEMENT
- PAE PUBLIC ACCESS EASEMENT
- PA&EA PUBLIC ACCESS AND EMERGENCY ACCESS EASEMENT
- U,PA&EA UTILITY, PUBLIC ACCESS AND EMERGENCY ACCESS EASEMENT
- FOUND ALIQUOT CORNER AS DESCRIBED
- FOUND MONUMENT AS DESCRIBED
- ◆ 2' WITNESS CORNER FOUND NAIL WITH BRASS CAP, LS 13485
- SET 24" OF #4 REBAR WITH A BLUE PLASTIC CAP STAMPED KS, LS 38209
- SET RIVET WITH A BRASS TAG STAMPED KS, LS 38209
- CALCULATED POSITION

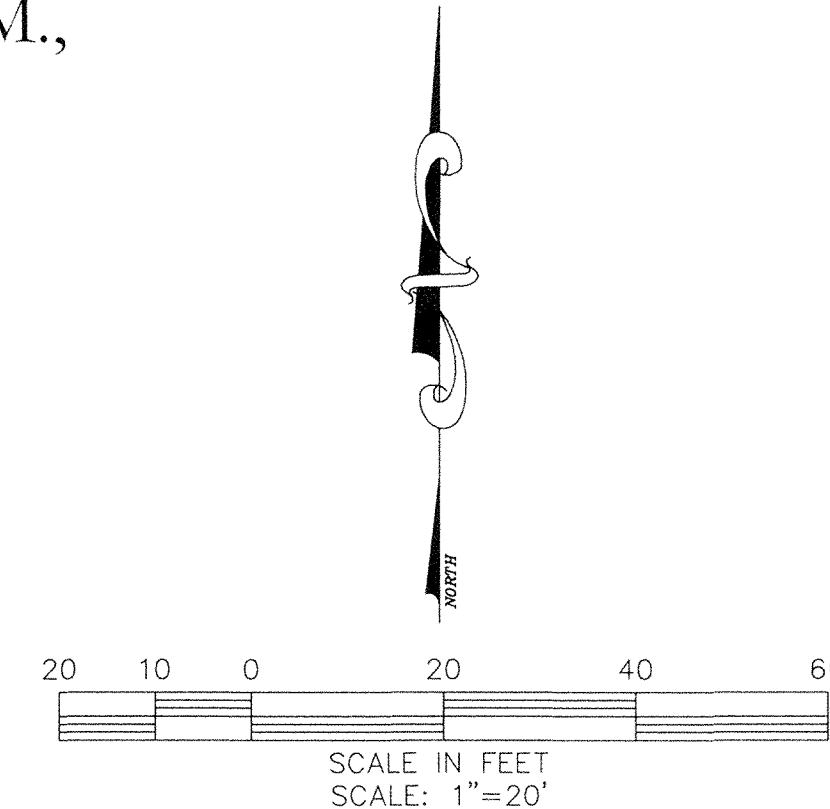

** FOR LINE AND CURVE TABLE
SEE SHEET 1 OF 4 **

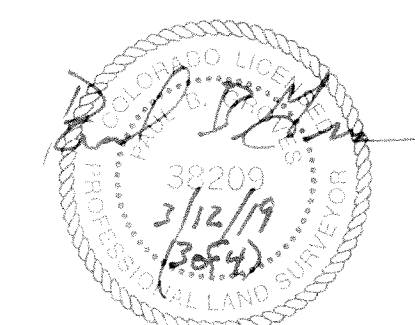

Paul B. Graves - On Behalf Of King Surveyors
Colorado Licensed Professional
Land Surveyor #38209

SHEET LAYOUT

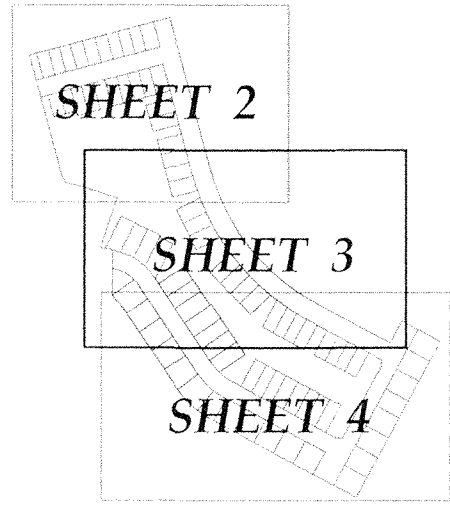

SEE SHEET 4 OF 4

SEE SHEET 4 OF 4

DATE:	3/7/2019
FILE NAME:	20160677B-SUB
SCALE:	1"=20'
DRAWN BY:	CSK
CHECKED BY:	PG

KING SURVEYORS
650 E. Garden Drive | Windsor, Colorado 80550
phone: (970) 686-5011 | email: contact@Kingsurveyors.com



REVISIONS:	DATE:
CADD CHECKED	CSK 1/21/19
REVISE PER COMMENTS	CSK 2/18/19
REVISE PER COMMENTS	CSK 3/5/19

Block 25, DISCOVERY OFFICE
PARK/SUPERIOR TOWN CENTER REPLAT NO. 2
FOR
CIVIL RESOURCES, LLC
P.O. BOX 680, FREDERICK, CO 80530

PROJECT #:
20160677-B

Final Subdivision Plat of Block 25, Discovery Office Park/Superior Town Center Replat No. 2

Being a Replat of Outlot G of Lot 1, Block 25 of Discovery Office Park/Superior Town Center Replat, and Superlot A, Block 25 of Discovery Office Park/Superior Town Center Replat No. 3, Situate in the West Half of Section 19, Township 1 South, Range 69 West of the 6th P.M., Town of Superior, County of Boulder, State of Colorado

DATE: 3/7/2019
FILE NAME: 20160677B-SUB
SCALE: 1"=20'
DRAWN BY: CSK
CHECKED BY: PG

KING SURVEYORS
650 E. Garden Drive | Windsor, Colorado 80550
phone: (970) 686-5011 | email: contact@Kingsurveyors.com



REVISIONS:	DATE:
CODE CHECKED	CSK 1/21/19
REVISE PER COMMENTS	CSK 2/7/19
REVISE PER COMMENTS	CSK 3/7/19

Block 25, DISCOVERY OFFICE
PARK/SUPERIOR TOWN CENTER REPLAT NO. 2
FOR
CIVIL RESOURCES, LLC
P.O. BOX 680, FREDERICK, CO 80530

PROJECT #:
20160677-B

4

