

SUPERIOR RESIDENTIAL FILING NO. 1B REPLAT NO. 6 FINAL PLAT

A REPLAT OF LOT 1, BLOCK 17; LOT 1, BLOCK 24; TRACT D1; TRACT H; SUPERLOT 5 AND PORTIONS OF RIGHT OF WAY, SUPERIOR TOWN CENTER FILING NO. 1B, REPLAT NO. 5, AND SUPERLOT 4B, DISCOVERY OFFICE PARK/SUPERIOR TOWN CENTER REPLAT NO. 3 BEING A PART OF SECTION 19, TOWNSHIP 1 SOUTH, RANGE 69 WEST OF THE 6th PRINCIPAL MERIDIAN, TOWN OF SUPERIOR, COUNTY OF BOULDER, STATE OF COLORADO
SHEET 1 OF 12
PLAT COVER

CERTIFICATE OF DEDICATION AND OWNERSHIP:

KNOW ALL MEN BY THESE PRESENTS THAT RC SUPERIOR, LLC, A DELAWARE LIMITED LIABILITY COMPANY AND THE TOWN OF SUPERIOR; BEING THE OWNER(S) OF CERTAIN LANDS IN BOULDER COUNTY, COLORADO, DESCRIBED AS FOLLOWS:

LOT 1, BLOCK 17; LOT 1, BLOCK 24; TRACT D1, TRACT H, SUPERLOT 5 AND PORTIONS OF RIGHT OF WAY, SUPERIOR TOWN CENTER FILING NO. 1B REPLAT NO. 5, ACCORDING TO THE PLAT THEREOF RECORDED JANUARY 4, 2018 UNDER RECEPTION NO. 03634333; AND SUPERLOT 4B, DISCOVERY OFFICE PARK/SUPERIOR TOWN CENTER REPLAT NO. 3, ACCORDING TO THE PLAT THEREOF RECORDED JANUARY 4, 2018 UNDER RECEPTION NO. 03634334, ALL IN SECTION NINETEEN (19), TOWNSHIP ONE SOUTH (T.1S.), RANGE SIXTY-NINE WEST (R.69W.), SIXTH PRINCIPAL MERIDIAN (6TH P.M.), TOWN OF SUPERIOR, COUNTY OF BOULDER, STATE OF COLORADO.

SAID PARCELS IN TOTAL CONTAIN 49.710 ACRES, MORE OR LESS (±).

HAVE BY THESE PRESENTS LAID OUT, PLATTED AND SUBDIVIDED THE SAME INTO LOTS, BLOCKS, OUTLOTS AND TRACTS, AS SHOWN ON THIS PLAT, UNDER THE NAME AND STYLE OF A SUBDIVISION PLAT OF SUPERIOR TOWN CENTER FILING NO. 1B REPLAT NO. 6 PRELIMINARY PLAT AND DO HEREBY DEDICATE TO THE PUBLIC THE EASEMENTS, TRACTS, OUTLOTS AND RIGHT OF WAY FOR PURPOSES SHOWN HEREIN.

I CERTIFY THAT RC SUPERIOR, LLC A DELAWARE LIMITED LIABILITY COMPANY CONSENTS TO THIS PLAT.
By: Superior Town Center ASI VII Holdings, LLC; By: Avanti Strategic Land Investors VII, L.L.P.; By: Avanti Properties Group II, L.L.P.;
By: Avanti Management Corporation, A Florida Corporation

EXECUTED THIS 20 DAY OF November, 2019.

OWNER: RC SUPERIOR, LLC, A DELAWARE LIMITED LIABILITY COMPANY

BY: [Signature]
NAME: MARVIN SHAPIRO TITLE: PRESIDENT

NOTARIAL CERTIFICATE

STATE OF Florida }
COUNTY OF Orange } SS

THE FOREGOING CERTIFICATE OF DEDICATION AND OWNERSHIP WAS ACKNOWLEDGED BEFORE ME THIS 20 DAY OF November, 2019.

SOLE MEMBER OF RC SUPERIOR, LLC, A DELAWARE LIMITED LIABILITY COMPANY.

MY COMMISSION EXPIRES 1/22/22 [Signature] (SEAL)
NOTARY PUBLIC



CERTIFICATE OF OWNERSHIP:

I CERTIFY THAT THE TOWN OF SUPERIOR CONSENTS TO THIS PLAT.

IN WITNESS WHEREOF I HEREBY SET MY HAND THIS 22nd DAY OF November, 2019.

[Signature]
MAYOR, TOWN OF SUPERIOR

NOTARIAL CERTIFICATE

STATE OF Colorado }
COUNTY OF Boulder } SS

THE FOREGOING CERTIFICATE OF OWNERSHIP WAS ACKNOWLEDGED BEFORE ME THIS 22nd DAY OF November, 2019, BY Clint Folsom

MY COMMISSION EXPIRES 2-5-2021 [Signature] (SEAL)
NOTARY PUBLIC

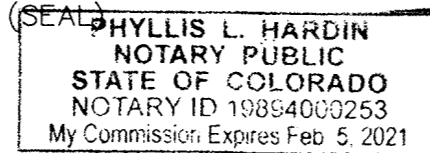

LENDER'S CONSENT AND SUBORDINATION:

THE UNDERSIGNED, BENEFICIARY UNDER A CERTAIN DEED OF TRUST ENCUMBERING THE PROPERTY, HEREBY EXPRESSLY CONSENTS TO AND JOINS IN THE EXECUTION AND RECORDING OF THIS PLAT, DEDICATION AND EASEMENTS SHOWN HEREON AND MAKES THE DEED OF TRUST SUBORDINATE HERETO.

THE UNDERSIGNED REPRESENTS THAT HE OR SHE HAS FULL POWER AND AUTHORITY TO EXECUTE THIS LENDER'S CONSENT AND SUBORDINATION ON BEHALF OF THE UNDERSIGNED.

Wells Fargo Bank
RC SUPERIOR, LLC, A DELAWARE LIMITED LIABILITY COMPANY.

BY: [Signature]

NAME: Joseph Kelley

TITLE: Vice President

ACKNOWLEDGEMENT

STATE OF FL }
COUNTY OF HILLSBOROUGH } SS

ACKNOWLEDGED BEFORE ME THIS 21st DAY OF NOVEMBER, 2019.

BY JOSEPH KELLEY AS VICE PRESIDENT

OF WELLS FARGO

MY COMMISSION EXPIRES 04/18/2021 [Signature] (SEAL)
NOTARY PUBLIC

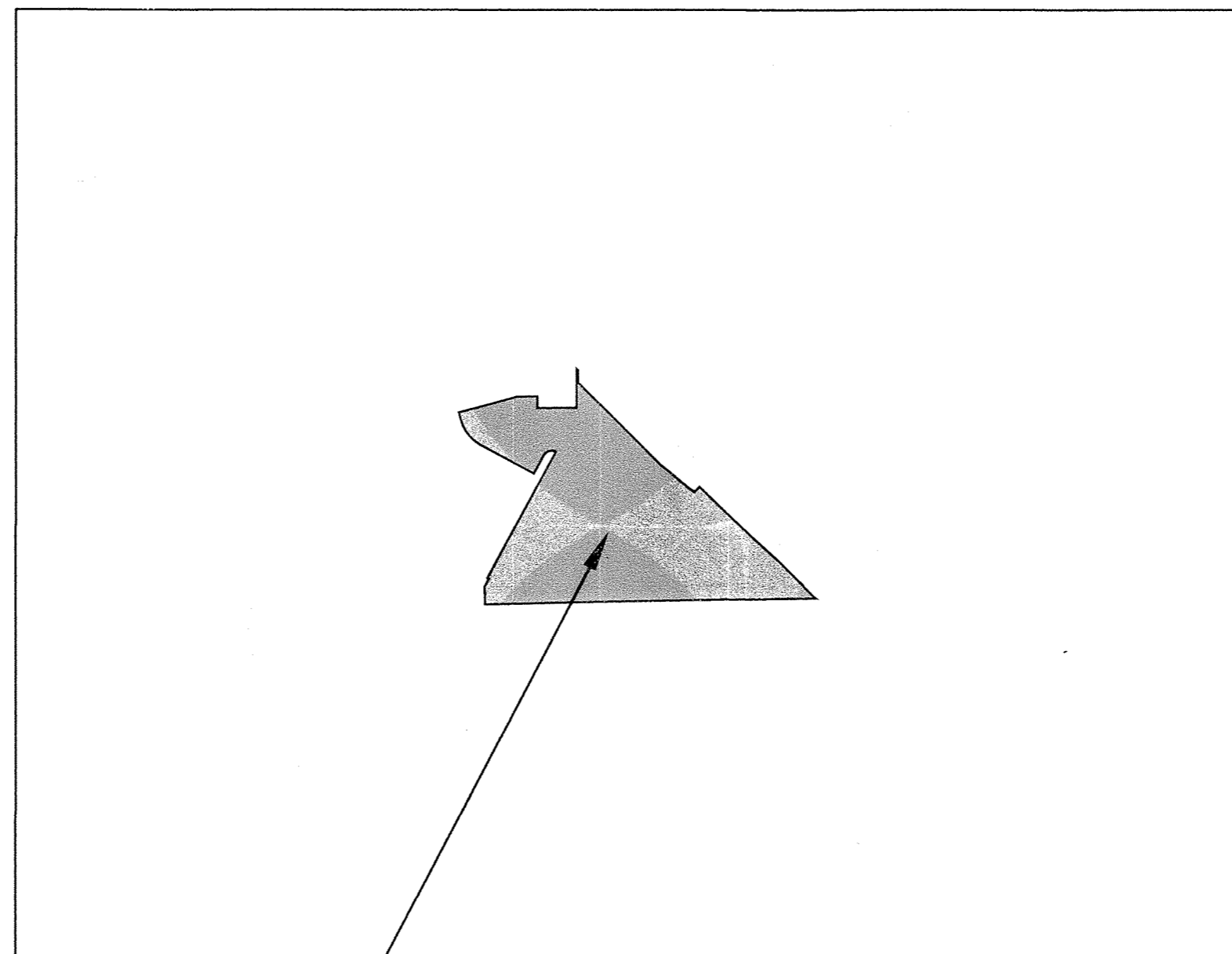
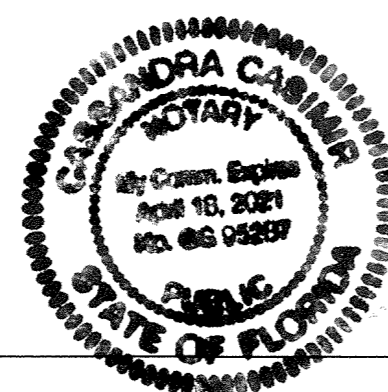

REPLAT AREA VICINITY MAP
SCALE: 1" = 1000'

OWNER'S ESTOPPEL CERTIFICATE:

WE, RC SUPERIOR, LLC A DELAWARE LIMITED LIABILITY COMPANY, AND THE TOWN OF SUPERIOR, THE OWNER(S) OF THE PROPERTY INCLUDED IN THE SUBDIVISION, CERTIFY THAT THIS PRELIMINARY PLAT AND THE SUBDIVISION IMPROVEMENT AGREEMENT TO BE EXECUTED IN CONNECTION HERewith IF REQUIRED, EMBODY THE ENTIRE AGREEMENT BETWEEN THE OWNER OF SAID PROPERTY AND THE TOWN WITH REGARD TO THE SUBDIVISION OF SAID PROPERTY, AND THAT THE OWNER IS NOT RELYING UPON ANY OTHER REPRESENTATIONS, WARRANTIES, UNDERSTANDINGS OR AGREEMENTS IN CONNECTION WITH ANY MATTER ENCOMPASSED BY THIS PLAT OR THE SUBDIVISION IMPROVEMENT AGREEMENT IF REQUIRED, EXCEPT AS SET FORTH HEREIN OR IN SAID SUBDIVISION IMPROVEMENT AGREEMENT.

BY: RC SUPERIOR, LLC, A DELAWARE LIMITED LIABILITY COMPANY

BY: THE TOWN OF SUPERIOR

BY: _____

PLANNING COMMISSION CERTIFICATE:

RECOMMENDED APPROVAL THIS 28th DAY OF August, 2019, BY THE TOWN OF SUPERIOR PLANNING COMMISSION, RESOLUTION NO. PC-4 SERIES 2019.

TOWN CLERK CERTIFICATE:

I HEREBY CERTIFY THAT THIS INSTRUMENT WAS ADOPTED BY THE BOARD OF TRUSTEES BY RESOLUTION NO. R-52, SERIES 2019 ON September 24, 2019, AND WAS FILED IN MY OFFICE ON THE 22nd DAY OF November, 2019, AT 3:00 O'CLOCK p. M.

[Signature]
TOWN CLERK

BOARD OF TRUSTEES CERTIFICATE:

APPROVED BY THE BOARD OF TRUSTEES OF THE TOWN OF SUPERIOR, STATE OF COLORADO.

WITNESS MY HAND THE CORPORATE SEAL OF THE TOWN OF SUPERIOR THIS 22nd

DAY OF November, 2019.

ATTEST: [Signature] TOWN CLERK [Signature] MAYOR



VACATION STATEMENT:

KNOW ALL MEN BY THESE PRESENTS THAT WE THE UNDERSIGNED, BEING THE OWNER(S) OF THE LAND DESCRIBED HEREIN, AND AS SHOWN ON THE ATTACHED MAP DO HEREBY VACATE ALL LOT LINES OF THE ABOVE DESCRIBED PARCEL OF LAND.

EASEMENT AND RIGHT OF WAY VACATION STATEMENT:

KNOW ALL MEN BY THESE PRESENTS: THAT WE, THE TOWN OF SUPERIOR, BEING OWNER(S) OF THE EASEMENTS AND RIGHTS OF WAY AS LISTED THEREIN:

A. A PORTION OF 30' IRRIGATION & ACCESS EASEMENT BEING A PART OF SUPERIOR TOWN CENTER FILING NO. 1B REPLAT, A SUBDIVISION RECORDED FEBRUARY 2, 2015 AS RECEPTION NO. 3425881 OF THE RECORDS OF BOULDER COUNTY.

B. A PORTION OF 12' PUBLIC ACCESS EASEMENT BEING A PART OF SUPERIOR TOWN CENTER FILING NO. 1B REPLAT, A SUBDIVISION RECORDED FEBRUARY 2, 2015 AS RECEPTION NO. 3425881 OF THE RECORDS OF BOULDER COUNTY.

C. A PORTION OF SUPERIOR DRIVE BEING A PART OF SUPERIOR TOWN CENTER FILING NO. 1B REPLAT NO. 5, A SUBDIVISION RECORDED JANUARY 4, 2018 AS RECEPTION NO. 3634333 OF THE RECORDS OF BOULDER COUNTY.

D. A PORTION OF JOSEPHINE WAY BEING A PART OF SUPERIOR TOWN CENTER FILING NO. 1B REPLAT NO. 5, A SUBDIVISION RECORDED JANUARY 4, 2018 AS RECEPTION NO. 3634333 OF THE RECORDS OF BOULDER COUNTY.

LOCATED IN SECTION 19, TOWNSHIP 1 SOUTH, RANGE 69 WEST, OF THE 6TH P.M., TOWN OF SUPERIOR, COUNTY OF BOULDER, STATE OF COLORADO, DO HEREBY VACATE THE EASEMENTS AS SHOWN HEREIN, AS LABELED "VACATED BY THIS PLAT AS SHOWN HATCHED".

IN WITNESS WHEREOF, AND BEING THE OWNER(S) OF SAID EASEMENTS AND RIGHTS OF WAY, WE HAVE SET OUR HANDS AND SEALS THIS 22nd DAY OF November, 2019

BY [Signature] AS Mayor

SURVEYOR'S CERTIFICATE:

I, KEVIN J. KUCHARCZYK, A REGISTERED LAND SURVEYOR, REGISTERED IN THE STATE OF COLORADO DO HEREBY CERTIFY THAT THERE ARE NO ROADS, PIPELINES, IRRIGATION DITCHES, OR OTHER EASEMENTS IN EVIDENCE OR KNOWN BY ME TO EXIST ON OR ACROSS THE HEREIN BEFORE DESCRIBED PROPERTY EXCEPT AS SHOWN ON THIS PLAT. I FURTHER CERTIFY THAT I HAVE PERFORMED THE SURVEY SHOWN HEREON, OR SUCH SURVEY WAS PREPARED UNDER MY DIRECT RESPONSIBILITY AND SUPERVISION, THAT THIS PLAT ACCURATELY REPRESENTS SAID SURVEY, AND THAT ALL MONUMENTS EXIST AS SHOWN HEREIN.

KEVIN J. KUCHARCZYK, PLS NO. 34591
FOR AND ON BEHALF OF CVL CONSULTANTS OF COLORADO, INC.
10333 E. DRY CREEK ROAD, SUITE 240
ENGLEWOOD CO, 80112

COUNTY CLERK AND RECORDER CERTIFICATE:

STATE OF COLORADO }
COUNTY OF BOULDER } SS.

THIS PLAT WAS FILED FOR RECORD IN THE OFFICE OF THE COUNTY CLERK AND RECORDER OF BOULDER COUNTY

AT 2:30 O'CLOCK p. M. ON THE 25th DAY OF November, 2019.

IN BOOK —, PAGE —, MAP —, RECEPTION NO. 03751120

COUNTY CLERK AND RECORDER [Signature] Notary Public Fees \$123.00
BY: [Signature] DEPUTY

ENGINEER/SURVEYOR

CVL CONSULTANTS
10333 E. Dry Creek Rd., Suite 240
Englewood, CO 80112
Tel: (720) 482-9526 / Fax: (720) 482-9546

03751120
Page 1 of 12
DF: \$0.00
11/25/2019 02:20:00
Boulder County Clerk, CO

A:\PROJECTS\SUPERIOR RESIDENTIAL\CS\REV\FINAL PLAT\SUPERIOR_COVER.DWG, MCHENR, 11/14/19

SUPERIOR RESIDENTIAL FILING NO. 1B REPLAT NO. 6 FINAL PLAT

A REPLAT OF LOT 1, BLOCK 17; LOT 1, BLOCK 24; TRACT D1; TRACT H; SUPERLOT 5 AND PORTIONS OF RIGHT OF WAY, SUPERIOR TOWN CENTER FILING NO. 1B, REPLAT NO. 5,
AND SUPERLOT 4B, DISCOVERY OFFICE PARK/SUPERIOR TOWN CENTER REPLAT NO. 3
BEING A PART OF SECTION 19, TOWNSHIP 1 SOUTH, RANGE 69 WEST OF THE 6th PRINCIPAL MERIDIAN,
TOWN OF SUPERIOR, COUNTY OF BOULDER, STATE OF COLORADO
SHEET 1 OF 12
PLAT COVER

CERTIFICATE OF DEDICATION AND OWNERSHIP:

KNOW ALL MEN BY THESE PRESENTS THAT RC SUPERIOR, LLC, A DELAWARE LIMITED LIABILITY COMPANY AND THE TOWN OF SUPERIOR; BEING THE OWNER(S) OF CERTAIN LANDS IN BOULDER COUNTY, COLORADO, DESCRIBED AS FOLLOWS:

LOT 1, BLOCK 17; LOT 1, BLOCK 24; TRACT D1; TRACT H, SUPERLOT 5 AND PORTIONS OF RIGHT OF WAY, SUPERIOR TOWN CENTER FILING NO. 1B REPLAT NO. 5, ACCORDING TO THE PLAT THEREOF RECORDED JANUARY 4, 2018 UNDER RECEPTION NO. 03634333; AND SUPERLOT 4B, DISCOVERY OFFICE PARK/SUPERIOR TOWN CENTER REPLAT NO. 3, ACCORDING TO THE PLAT THEREOF RECORDED JANUARY 4, 2018 UNDER RECEPTION NO. 03634334, ALL IN SECTION NINETEEN (19), TOWNSHIP ONE SOUTH (T.1S.), RANGE SIXTY-NINE WEST (R.69W.), SIXTH PRINCIPAL MERIDIAN (6TH P.M.), TOWN OF SUPERIOR, COUNTY OF BOULDER, STATE OF COLORADO.

SAID PARCELS IN TOTAL CONTAIN 49.710 ACRES, MORE OR LESS (±).

HAVE BY THESE PRESENTS LAID OUT, PLATTED AND SUBDIVIDED THE SAME INTO LOTS, BLOCKS, OUTLOTS AND TRACTS, AS SHOWN ON THIS PLAT, UNDER THE NAME AND STYLE OF A SUBDIVISION PLAT OF SUPERIOR TOWN CENTER FILING NO. 1B REPLAT NO. 6 PRELIMINARY PLAT AND DO HEREBY DEDICATE TO THE PUBLIC THE EASEMENTS, TRACTS, OUTLOTS AND RIGHT OF WAY FOR PURPOSES SHOWN HEREIN.

I CERTIFY THAT RC SUPERIOR, LLC A DELAWARE LIMITED LIABILITY COMPANY CONSENTS TO THIS PLAT.

EXECUTED THIS _____ DAY OF _____, 2019.

OWNER: RC SUPERIOR, LLC, A DELAWARE LIMITED LIABILITY COMPANY

BY: _____
NAME: MARVIN SHAPIRO TITLE: PRESIDENT

NOTARIAL CERTIFICATE

STATE OF _____)
COUNTY OF _____) SS

THE FOREGOING CERTIFICATE OF DEDICATION AND OWNERSHIP WAS ACKNOWLEDGED BEFORE ME THIS _____ DAY OF _____, 2019,

SOLE MEMBER OF RC SUPERIOR, LLC, A DELAWARE LIMITED LIABILITY COMPANY.

MY COMMISSION EXPIRES _____ (SEAL)
NOTARY PUBLIC

CERTIFICATE OF OWNERSHIP:

I CERTIFY THAT THE TOWN OF SUPERIOR CONSENTS TO THIS PLAT.

IN WITNESS WHEREOF I HEREBY SET MY HAND THIS _____ DAY OF _____, 2019.

MAYOR, TOWN OF SUPERIOR

NOTARIAL CERTIFICATE

STATE OF _____)
COUNTY OF _____) SS

THE FOREGOING CERTIFICATE OF OWNERSHIP WAS ACKNOWLEDGED BEFORE ME THIS _____ DAY OF _____, 2019, BY _____

MY COMMISSION EXPIRES _____ (SEAL)
NOTARY PUBLIC

LENDER'S CONSENT AND SUBORDINATION:

THE UNDERSIGNED, BENEFICIARY UNDER A CERTAIN DEED OF TRUST ENCUMBERING THE PROPERTY, HEREBY EXPRESSLY CONSENTS TO AND JOINS IN THE EXECUTION AND RECORDING OF THIS PLAT, DEDICATION AND EASEMENTS SHOWN HEREON AND MAKES THE DEED OF TRUST SUBORDINATE HERETO.

THE UNDERSIGNED REPRESENTS THAT HE OR SHE HAS FULL POWER AND AUTHORITY TO EXECUTE THIS LENDER'S CONSENT AND SUBORDINATION ON BEHALF OF THE UNDERSIGNED.

RC SUPERIOR, LLC, A DELAWARE LIMITED LIABILITY COMPANY

BY: _____
NAME: _____

TITLE: _____

ACKNOWLEDGEMENT

STATE OF _____)
COUNTY OF _____) SS

ACKNOWLEDGED BEFORE ME THIS _____ DAY OF _____, 2019,

BY _____ AS _____
OF _____

MY COMMISSION EXPIRES _____ (SEAL)
NOTARY PUBLIC

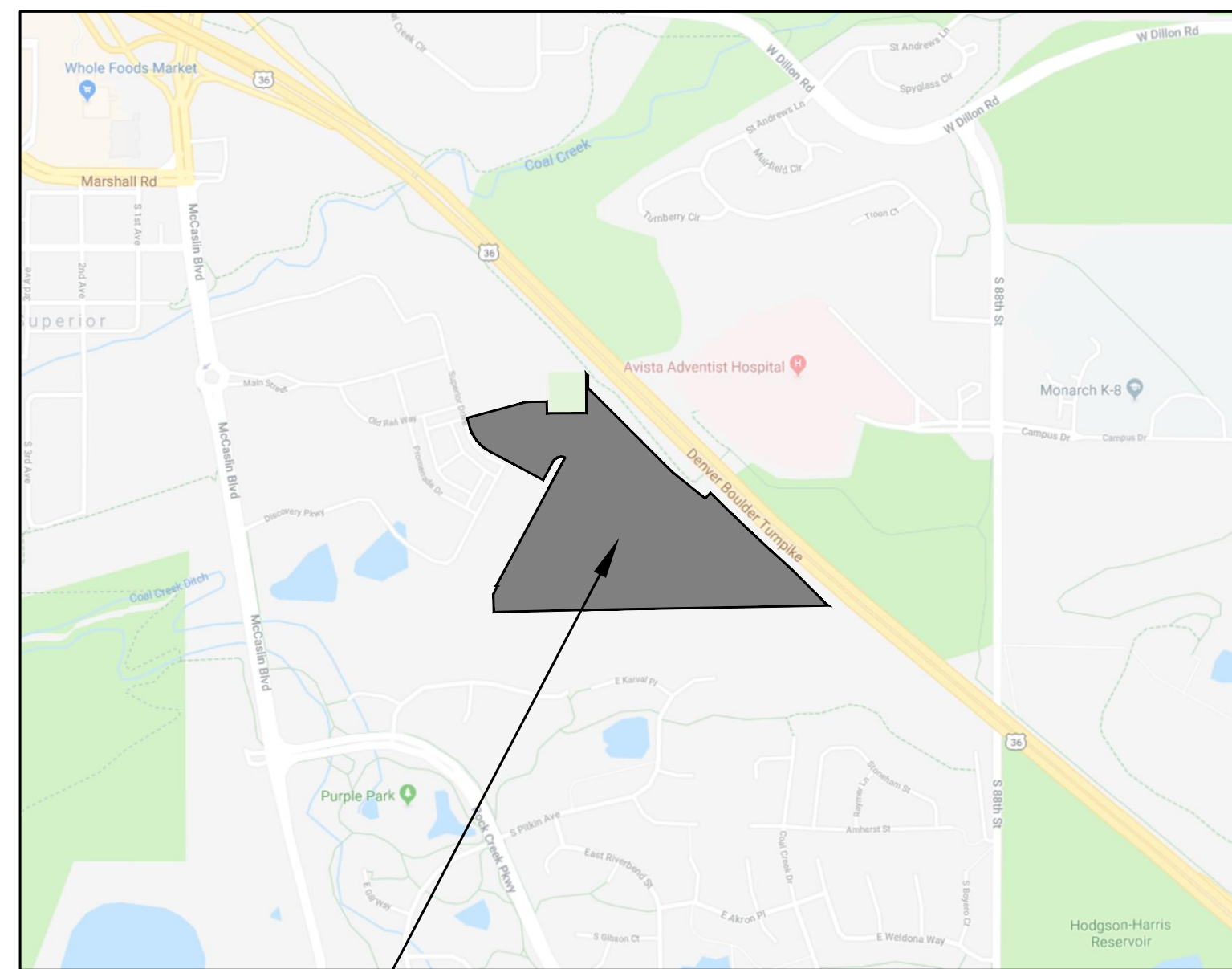

REPLAT AREA **VICINITY MAP**
SCALE: 1" = 1000'

OWNER'S ESTOPPEL CERTIFICATE:

WE, RC SUPERIOR, LLC, A DELAWARE LIMITED LIABILITY COMPANY, AND THE TOWN OF SUPERIOR, THE OWNER(S) OF THE PROPERTY INCLUDED IN THE SUBDIVISION, CERTIFY THAT THIS PRELIMINARY PLAT AND THE SUBDIVISION IMPROVEMENT AGREEMENT TO BE EXECUTED IN CONNECTION HERewith IF REQUIRED, EMBODY THE ENTIRE AGREEMENT BETWEEN THE OWNER OF SAID PROPERTY AND THE TOWN WITH REGARD TO THE SUBDIVISION OF SAID PROPERTY, AND THAT THE OWNER IS NOT RELYING UPON ANY OTHER REPRESENTATIONS, WARRANTIES, UNDERSTANDINGS OR AGREEMENTS IN CONNECTION WITH ANY MATTER ENCOMPASSED BY THIS PLAT OR THE SUBDIVISION IMPROVEMENT AGREEMENT IF REQUIRED, EXCEPT AS SET FORTH HEREIN OR IN SAID SUBDIVISION IMPROVEMENT AGREEMENT.

BY: RC SUPERIOR, LLC, A DELAWARE LIMITED LIABILITY COMPANY

BY: THE TOWN OF SUPERIOR

BY: _____

PLANNING COMMISSION CERTIFICATE:

RECOMMENDED APPROVAL THIS _____ DAY OF _____, 2019, BY THE
TOWN OF SUPERIOR PLANNING COMMISSION, RESOLUTION NO. PC _____ SERIES 20 _____.

TOWN CLERK CERTIFICATE:

I HEREBY CERTIFY THAT THIS INSTRUMENT WAS ADOPTED BY THE BOARD OF TRUSTEES BY RESOLUTION
NO. _____, SERIES 20 _____ ON _____, 2019, AND WAS FILED
IN MY OFFICE ON THE _____ DAY OF _____, 2019, AT _____ O'CLOCK _____ M.

TOWN CLERK

BOARD OF TRUSTEES CERTIFICATE:

APPROVED BY THE BOARD OF TRUSTEES OF THE TOWN OF SUPERIOR, STATE OF COLORADO.

WITNESS MY HAND THE CORPORATE SEAL OF THE TOWN OF SUPERIOR THIS _____

DAY OF _____, 2019.

ATTEST: _____ TOWN CLERK _____ MAYOR

VACATION STATEMENT:

KNOW ALL MEN BY THESE PRESENTS THAT WE THE UNDERSIGNED, BEING THE OWNER(S) OF THE LAND DESCRIBED HEREIN, AND AS SHOWN ON THE ATTACHED MAP DO HEREBY VACATE ALL LOT LINES OF THE ABOVE DESCRIBED PARCEL OF LAND.

EASEMENT AND RIGHT OF WAY VACATION STATEMENT:

KNOW ALL MEN BY THESE PRESENTS: THAT WE, THE TOWN OF SUPERIOR, BEING OWNER(S) OF THE EASEMENTS AND RIGHTS OF WAY AS LISTED THEREIN:

- A. A PORTION OF 30' IRRIGATION & ACCESS EASEMENT BEING A PART OF SUPERIOR TOWN CENTER FILING NO. 1B REPLAT, A SUBDIVISION RECORDED FEBRUARY 2, 2015 AS RECEPTION NO. 3425881 OF THE RECORDS OF BOULDER COUNTY.
- B. A PORTION OF 12' PUBLIC ACCESS EASEMENT BEING A PART OF SUPERIOR TOWN CENTER FILING NO. 1B REPLAT, A SUBDIVISION RECORDED FEBRUARY 2, 2015 AS RECEPTION NO. 3425881 OF THE RECORDS OF BOULDER COUNTY.
- C. A PORTION OF SUPERIOR DRIVE BEING A PART OF SUPERIOR TOWN CENTER FILING NO. 1B REPLAT NO. 5, A SUBDIVISION RECORDED JANUARY 4, 2018 AS RECEPTION NO. 3634333 OF THE RECORDS OF BOULDER COUNTY.
- D. A PORTION OF JOSEPHINE WAY BEING A PART OF SUPERIOR TOWN CENTER FILING NO. 1B REPLAT NO. 5, A SUBDIVISION RECORDED JANUARY 4, 2018 AS RECEPTION NO. 3634333 OF THE RECORDS OF BOULDER COUNTY.

LOCATED IN SECTION 19, TOWNSHIP 1 SOUTH, RANGE 69 WEST, OF THE 6TH P.M., TOWN OF SUPERIOR, COUNTY OF BOULDER, STATE OF COLORADO, DO HEREBY VACATE THE EASEMENTS AS SHOWN HEREIN, AS LABELED "VACATED BY THIS PLAT AS SHOWN HATCHED".

IN WITNESS WHEREOF, AND BEING THE OWNER(S) OF SAID EASEMENTS AND RIGHTS OF WAY. WE HAVE SET OUR HANDS AND SEALS THIS _____ DAY OF _____, 2019

BY _____ AS _____

SURVEYOR'S CERTIFICATE:

I, KEVIN J. KUCHARCZYK, A REGISTERED LAND SURVEYOR, REGISTERED IN THE STATE OF COLORADO DO HEREBY CERTIFY THAT THERE ARE NO ROADS, PIPELINES, IRRIGATION DITCHES, OR OTHER EASEMENTS IN EVIDENCE OR KNOWN BY ME TO EXIST ON OR ACROSS THE HEREIN BEFORE DESCRIBED PROPERTY EXCEPT AS SHOWN ON THIS PLAT. I FURTHER CERTIFY THAT I HAVE PERFORMED THE SURVEY SHOWN HEREON, OR SUCH SURVEY WAS PREPARED UNDER MY DIRECT RESPONSIBILITY AND SUPERVISION, THAT THIS PLAT ACCURATELY REPRESENTS SAID SURVEY, AND THAT ALL MONUMENTS EXIST AS SHOWN HEREIN.

KEVIN J. KUCHARCZYK, PLS NO. 34591
FOR AND ON BEHALF OF CIVIL CONSULTANTS OF COLORADO, INC.
10333 E. DRY CREEK ROAD, SUITE 240
ENGLEWOOD CO, 80112

COUNTY CLERK AND RECORDER CERTIFICATE:

STATE OF COLORADO)
COUNTY OF BOULDER) SS

THIS PLAT WAS FILED FOR RECORD IN THE OFFICE OF THE COUNTY CLERK AND RECORDER OF BOULDER COUNTY

AT _____ O'CLOCK _____ M. ON THE _____ DAY OF _____, 2019,

IN BOOK _____, PAGE _____, MAP _____, RECEPTION NO. _____

COUNTY CLERK AND RECORDER

BY: _____ DEPUTY

ENGINEER/SURVEYOR

CIVIL CONSULTANTS
10333 E. Dry Creek Rd., Suite 240
Englewood, CO 80112
Tel: (720) 482-9526 / Fax: (720) 482-9546

SUPERIOR RESIDENTIAL FILING NO. 1B REPLAT NO. 6 FINAL PLAT

A REPLAT OF LOT 1, BLOCK 17; LOT 1, BLOCK 24; TRACT D1; TRACT H; SUPERLOT 5 AND PORTIONS OF RIGHT OF WAY, SUPERIOR TOWN CENTER FILING NO. 1B, REPLAT NO. 5,
AND SUPERLOT 4B, DISCOVERY OFFICE PARK/SUPERIOR TOWN CENTER REPLAT NO. 3
BEING A PART OF SECTION 19, TOWNSHIP 1 SOUTH, RANGE 69 WEST OF THE 6th PRINCIPAL MERIDIAN,
TOWN OF SUPERIOR, COUNTY OF BOULDER, STATE OF COLORADO
SHEET 2 OF 12

PLAT NOTES / TRACT TABLE

SURVEYOR'S NOTES:

THE DIMENSIONS, LOCATIONS, AND OTHER INFORMATION REGARDING RECORDED RIGHTS-OF-WAY AND EASEMENTS WERE DERIVED FROM COPIES OF THE ACTUAL RECORDED DOCUMENTS. THE UNDERSIGNED SURVEYOR DID NOT PERSONALLY SEARCH THE PUBLIC RECORDS TO DETERMINE THE RECORDED RIGHTS-OF-WAY AND EASEMENTS AFFECTING THE PROPERTY, BUT INSTEAD RESEARCH WAS OBTAINED FROM LAND TITLE GUARANTEE COMPANY. THE RESEARCH IS BELIEVED BY THE UNDERSIGNED TO BE RELIABLE, COMPLETE AND CORRECT, AND IS NOT CONTRADICTED BY ANY OTHER INFORMATION KNOWN TO THE SURVEYOR. THIS DISCLOSURE IS PROVIDED TO COMPLY WITH 38-51-106, C.R.S. AND FOR NO OTHER PURPOSE.

THE BASIS OF BEARINGS FOR THIS PLAT IS THE SOUTH LINE OF THE NORTHEAST QUARTER OF SAID SECTION 19, ASSUMED TO BEAR NORTH 88°53'47" EAST, BEING A GRID BEARING OF THE COLORADO STATE PLANE COORDINATE SYSTEM, NORTH ZONE, NORTH AMERICAN DATUM 1983/92, A DISTANCE OF 2652.07 FEET, BASED ON THE MONUMENTS AS SHOWN HEREON, WITH ALL BEARINGS HEREIN RELATIVE THERETO.

ACCORDING TO COLORADO LAW YOU MUST COMMENCE ANY LEGAL ACTION BASED UPON ANY DEFECT IN THIS SURVEY WITHIN THREE YEARS AFTER YOU FIRST DISCOVER SUCH DEFECT. IN NO EVENT MAY ANY ACTION BASED UPON ANY DEFECT IN THIS SURVEY BE COMMENCED MORE THAN TEN YEARS FROM THE DATE OF THE CERTIFICATION SHOWN HEREON.

ANY PERSON WHO KNOWINGLY REMOVES, ALTERS OR DEFACES ANY PUBLIC LAND SURVEY MONUMENT OR LAND BOUNDARY MONUMENT OR ACCESSORY, COMMITS A CLASS TWO (2) MISDEMEANOR PURSUANT TO STATE STATUTE 18-4-508, C.R.S.

THE LINEAL UNIT USED IN THE PREPARATION OF THIS PLAT IS THE U.S. SURVEY FOOT AS DEFINED BY THE UNITED STATES DEPARTMENT OF COMMERCE, NATIONAL INSTITUTE OF STANDARDS AND TECHNOLOGY.

THIS SURVEY DOES NOT CONSTITUTE A TITLE SEARCH BY CVL CONSULTANTS OF COLORADO, INC. TO DETERMINE OWNERSHIP OR EASEMENTS OF RECORD. FOR ALL INFORMATION REGARDING EASEMENTS, RIGHTS-OF-WAY, AND TITLE OF RECORD, CVL CONSULTANTS OF COLORADO, INC. RELIED UPON LAND TITLE GUARANTEE COMPANY COMMITMENT NO. ABZ70568072-8, WITH AN EFFECTIVE DATE OF NOVEMBER 12, 2019 AT 5:00:00.

VIEW SENSITIVE AREA (VSA) INCLUDES BLOCK 16 LOTS 1-18, BLOCK 17 LOTS 1-11, BLOCK 18 LOTS 1-6, BLOCK 24 LOTS 1-19 AND 46-48. THE MORE RESTRICTIVE HEIGHT CONSTRAINT BETWEEN THE SUPERIOR TOWN CENTER PLANNED DEVELOPMENT (PD) ALLOWANCES AND VSA SHALL BE USED FOR THESE LOTS PER THE SUPERIOR TOWN CENTER PLANNED DEVELOPMENT RECORDED AT RECEPTION NO. 03659530.

OWNERSHIP, MAINTENANCE AND USE TABLE				
NAME	AREA	USE	OWNERSHIP	MAINTENANCE
OUTLOT A	0.427 AC	DRIVE LANE / UTILITIES	METRO DISTRICT	METRO DISTRICT
OUTLOT B	0.035 AC	OPEN SPACE / DRAINAGE / UTILITIES	METRO DISTRICT	METRO DISTRICT
OUTLOT C	0.078 AC	OPEN SPACE / DRAINAGE / UTILITIES	METRO DISTRICT	METRO DISTRICT
OUTLOT D	0.567 AC	DRIVE LANE / UTILITIES	METRO DISTRICT	METRO DISTRICT
OUTLOT E	0.047 AC	OPEN SPACE / DRAINAGE / UTILITIES	METRO DISTRICT	METRO DISTRICT
OUTLOT F	0.044 AC	ACCESS / UTILITIES	TOWN OF SUPERIOR	TOWN OF SUPERIOR
OUTLOT G	0.047 AC	OPEN SPACE / DRAINAGE / UTILITIES	METRO DISTRICT	METRO DISTRICT
OUTLOT H	0.044 AC	ACCESS / UTILITIES	TOWN OF SUPERIOR	TOWN OF SUPERIOR
OUTLOT I	0.125 AC	OPEN SPACE / DRAINAGE / UTILITIES	METRO DISTRICT	METRO DISTRICT
OUTLOT J	0.279 AC	DRIVE LANE / UTILITIES	METRO DISTRICT	METRO DISTRICT
OUTLOT K	0.035 AC	ACCESS / UTILITIES	TOWN OF SUPERIOR	TOWN OF SUPERIOR
OUTLOT L	0.315 AC	OPEN SPACE / DRAINAGE / UTILITIES	METRO DISTRICT	METRO DISTRICT
OUTLOT M	0.041 AC	ACCESS / UTILITIES	TOWN OF SUPERIOR	TOWN OF SUPERIOR
OUTLOT N	0.151 AC	DRIVE LANE / UTILITIES	METRO DISTRICT	METRO DISTRICT
OUTLOT O	0.033 AC	ACCESS / UTILITIES	TOWN OF SUPERIOR	TOWN OF SUPERIOR
OUTLOT P	0.655 AC	OPEN SPACE / DRAINAGE / UTILITIES	METRO DISTRICT	METRO DISTRICT
OUTLOT Q	0.364 AC	DRIVE LANE / UTILITIES	METRO DISTRICT	METRO DISTRICT
OUTLOT R	0.170 AC	DRIVE LANE / UTILITIES	METRO DISTRICT	METRO DISTRICT
OUTLOT S	2.877 AC	OPEN SPACE / DRAINAGE / UTILITIES	METRO DISTRICT	METRO DISTRICT
OUTLOT T	0.061 AC	ACCESS / UTILITIES	TOWN OF SUPERIOR	TOWN OF SUPERIOR
OUTLOT U	0.308 AC	DRIVE LANE / UTILITIES	METRO DISTRICT	METRO DISTRICT
OUTLOT V	0.023 AC	ACCESS / UTILITIES	TOWN OF SUPERIOR	TOWN OF SUPERIOR
OUTLOT W	0.409 AC	DRIVE LANE / UTILITIES	METRO DISTRICT	METRO DISTRICT
OUTLOT X	0.205 AC	OPEN SPACE / DRAINAGE / UTILITIES	METRO DISTRICT	METRO DISTRICT
OUTLOT Y	0.020 AC	ACCESS / UTILITIES	TOWN OF SUPERIOR	TOWN OF SUPERIOR
OUTLOT Z	0.223 AC	DRIVE LANE / UTILITIES	METRO DISTRICT	METRO DISTRICT
OUTLOT AA	0.051 AC	ACCESS / UTILITIES	TOWN OF SUPERIOR	TOWN OF SUPERIOR
OUTLOT BB	0.257 AC	OPEN SPACE / DRAINAGE / UTILITIES	METRO DISTRICT	METRO DISTRICT
OUTLOT CC	0.052 AC	ACCESS / UTILITIES	TOWN OF SUPERIOR	TOWN OF SUPERIOR
OUTLOT DD	0.264 AC	DRIVE LANE / UTILITIES	METRO DISTRICT	METRO DISTRICT
OUTLOT EE	0.023 AC	ACCESS / UTILITIES	TOWN OF SUPERIOR	TOWN OF SUPERIOR
OUTLOT FF	0.029 AC	OPEN SPACE / DRAINAGE / UTILITIES	METRO DISTRICT	METRO DISTRICT
OUTLOT GG	0.649 AC	DRIVE LANE / UTILITIES	METRO DISTRICT	METRO DISTRICT
OUTLOT HH	0.041 AC	OPEN SPACE / DRAINAGE / UTILITIES	METRO DISTRICT	METRO DISTRICT
OUTLOT II	0.032 AC	ACCESS / UTILITIES	TOWN OF SUPERIOR	TOWN OF SUPERIOR
OUTLOT JJ	0.058 AC	ACCESS / UTILITIES	TOWN OF SUPERIOR	TOWN OF SUPERIOR
OUTLOT KK	0.034 AC	OPEN SPACE / DRAINAGE / UTILITIES	METRO DISTRICT	METRO DISTRICT
OUTLOT LL	0.011 AC	ACCESS / UTILITIES	TOWN OF SUPERIOR	TOWN OF SUPERIOR
OUTLOT MM	0.058 AC	OPEN SPACE / DRAINAGE / UTILITIES	METRO DISTRICT	METRO DISTRICT
OUTLOT NN	1.027 AC	DRIVE LANE / UTILITIES	METRO DISTRICT	METRO DISTRICT
OUTLOT OO	0.069 AC	ACCESS / UTILITIES	TOWN OF SUPERIOR	TOWN OF SUPERIOR
OUTLOT PP	0.117 AC	OPEN SPACE / DRAINAGE / UTILITIES	METRO DISTRICT	METRO DISTRICT
OUTLOT QQ	0.172 AC	OPEN SPACE / DRAINAGE / UTILITIES	METRO DISTRICT	METRO DISTRICT
OUTLOT RR	0.170 AC	OPEN SPACE / DRAINAGE / UTILITIES	METRO DISTRICT	METRO DISTRICT
OUTLOT SS	0.060 AC	OPEN SPACE / DRAINAGE / UTILITIES	METRO DISTRICT	METRO DISTRICT
OUTLOT TT	0.060 AC	OPEN SPACE / DRAINAGE / UTILITIES	METRO DISTRICT	METRO DISTRICT
OUTLOT UU	0.098 AC	OPEN SPACE / DRAINAGE / UTILITIES	METRO DISTRICT	METRO DISTRICT
OUTLOT VV	0.015 AC	ACCESS / UTILITIES	TOWN OF SUPERIOR	TOWN OF SUPERIOR
OUTLOT WW	0.035 AC	ACCESS / UTILITIES	TOWN OF SUPERIOR	TOWN OF SUPERIOR
OUTLOT XX	0.049 AC	ACCESS / UTILITIES	TOWN OF SUPERIOR	TOWN OF SUPERIOR
OUTLOT YY	0.016 AC	ACCESS / UTILITIES	TOWN OF SUPERIOR	TOWN OF SUPERIOR
OUTLOT AAA	0.043 AC	ACCESS / UTILITIES	TOWN OF SUPERIOR	TOWN OF SUPERIOR
OUTLOT BBB	0.049 AC	ACCESS / UTILITIES	TOWN OF SUPERIOR	TOWN OF SUPERIOR
OUTLOT CCC	0.048 AC	ACCESS / UTILITIES	TOWN OF SUPERIOR	TOWN OF SUPERIOR
OUTLOT DDD	0.060 AC	ACCESS / UTILITIES	TOWN OF SUPERIOR	TOWN OF SUPERIOR
OUTLOT EEE	0.012 AC	ACCESS / UTILITIES	TOWN OF SUPERIOR	TOWN OF SUPERIOR
OUTLOT FFF	0.012 AC	ACCESS / UTILITIES	TOWN OF SUPERIOR	TOWN OF SUPERIOR
OUTLOT GGG	0.023 AC	ACCESS / UTILITIES	TOWN OF SUPERIOR	TOWN OF SUPERIOR
OUTLOT HHH	0.021 AC	ACCESS / UTILITIES	TOWN OF SUPERIOR	TOWN OF SUPERIOR
OUTLOT III	0.036 AC	ACCESS / UTILITIES	TOWN OF SUPERIOR	TOWN OF SUPERIOR
OUTLOT JJJ	0.042 AC	ACCESS / UTILITIES	TOWN OF SUPERIOR	TOWN OF SUPERIOR
TRACT DI	6.008 AC	OPEN SPACE / DRAINAGE / UTILITIES	TOWN OF SUPERIOR	TOWN OF SUPERIOR
TRACT G	1.857 AC	OPEN SPACE / DRAINAGE / UTILITIES	TOWN OF SUPERIOR	TOWN OF SUPERIOR
TRACT H	6.711 AC	OPEN SPACE / DRAINAGE / UTILITIES	TOWN OF SUPERIOR	TOWN OF SUPERIOR

* DRIVE LANES INCLUDE EMERGENCY ACCESS EASEMENTS AND PUBLIC ACCESS AND UTILITY EASEMENTS.

LAND USE TABLE		
DESCRIPTION	ACRES	PERCENTAGE
SINGLE FAMILY LOTS	9.406 AC	18.92%
MULTI-FAMILY LOTS	6.871 AC	13.82%
PUBLIC OUTLOTS / TRACTS	15.616 AC	31.41%
METRO DISTRICT OUTLOTS	10.317 AC	20.76%
DEDICATED RIGHT OF WAY	7.500 AC	15.09%
TOTALS	49.710 AC	100%

SUPERIOR RESIDENTIAL FILING NO. 1B REPLAT NO. 6 FINAL PLAT

A REPLAT OF LOT 1, BLOCK 17; LOT 1, BLOCK 24; TRACT D1; TRACT H; SUPERLOT 5 AND PORTIONS OF RIGHT OF WAY, SUPERIOR TOWN CENTER FILING NO. 1B, REPLAT NO. 5, AND SUPERLOT 4B, DISCOVERY OFFICE PARK/SUPERIOR TOWN CENTER REPLAT NO. 3 BEING A PART OF SECTION 19, TOWNSHIP 1 SOUTH, RANGE 69 WEST OF THE 6th PRINCIPAL MERIDIAN, TOWN OF SUPERIOR, COUNTY OF BOULDER, STATE OF COLORADO

SHEET 3 OF 12
OVERALL PLAT MAP

NOTE:
VIEW SENSITIVE AREA (VSA) INCLUDES BLOCK 16 LOTS 1-18, BLOCK 17 LOTS 1-11, BLOCK 18 LOTS 1-6, BLOCK 24 LOTS 1-19 AND 46-48. THE MORE RESTRICTIVE HEIGHT CONSTRAINT BETWEEN THE PD ALLOWANCES AND VSA SHALL BE USED IN THIS AREA.

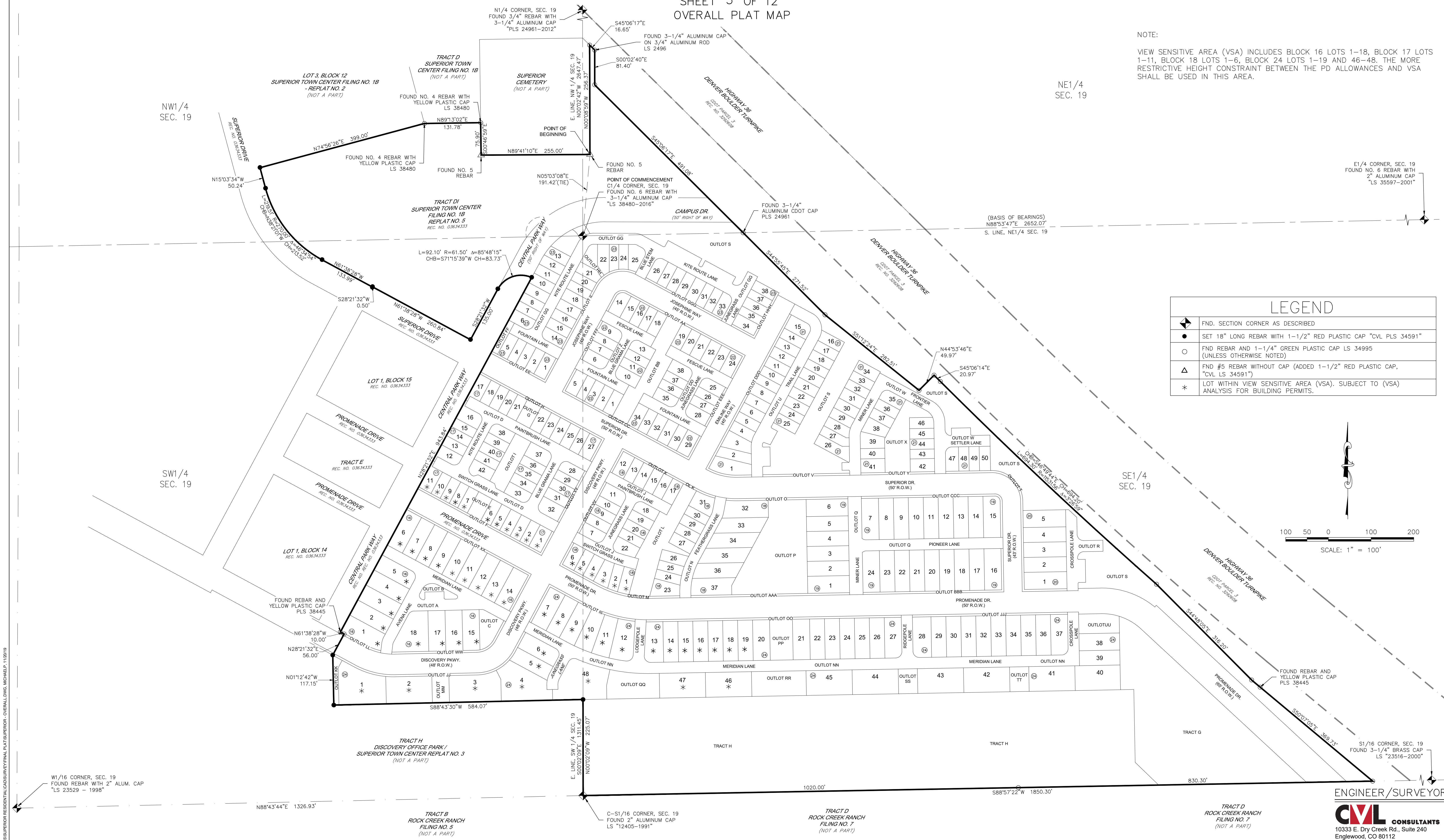

LEGEND	
◆	FND. SECTION CORNER AS DESCRIBED
●	SET 18" LONG REBAR WITH 1-1/2" RED PLASTIC CAP "CVL PLS 34591"
○	FND REBAR AND 1-1/4" GREEN PLASTIC CAP LS 34995 (UNLESS OTHERWISE NOTED)
△	FND #5 REBAR WITHOUT CAP (ADDED 1-1/2" RED PLASTIC CAP, "CVL LS 34591")
*	LOT WITHIN VIEW SENSITIVE AREA (VSA). SUBJECT TO (VSA) ANALYSIS FOR BUILDING PERMITS.

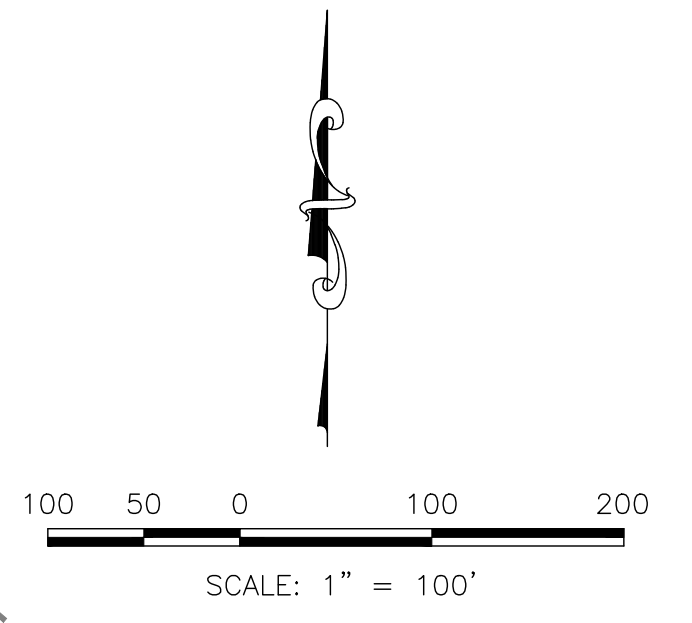

PROJECT: SUPERIOR RESIDENTIAL CAD SURVEY FINAL PLAT SUPERIOR - OVERALL DWG MICHAEL P. 11/2019

ENGINEER/SURVEYOR

CVL CONSULTANTS
10333 E. Dry Creek Rd., Suite 240
Englewood, CO 80112
Tel: (720) 482-9526 / Fax: (720) 482-9546

SUPERIOR RESIDENTIAL FILING NO. 1B REPLAT NO. 6 FINAL PLAT

A REPLAT OF LOT 1, BLOCK 17; LOT 1, BLOCK 24; TRACT D1; TRACT H; SUPERLOT 5 AND PORTIONS OF RIGHT OF WAY, SUPERIOR TOWN CENTER FILING NO. 1B, REPLAT NO. 5, AND SUPERLOT 4B, DISCOVERY OFFICE PARK/SUPERIOR TOWN CENTER REPLAT NO. 3 BEING A PART OF SECTION 19, TOWNSHIP 1 SOUTH, RANGE 69 WEST OF THE 6th PRINCIPAL MERIDIAN, TOWN OF SUPERIOR, COUNTY OF BOULDER, STATE OF COLORADO

SHEET 4 OF 12
EASEMENT VACATION MAP

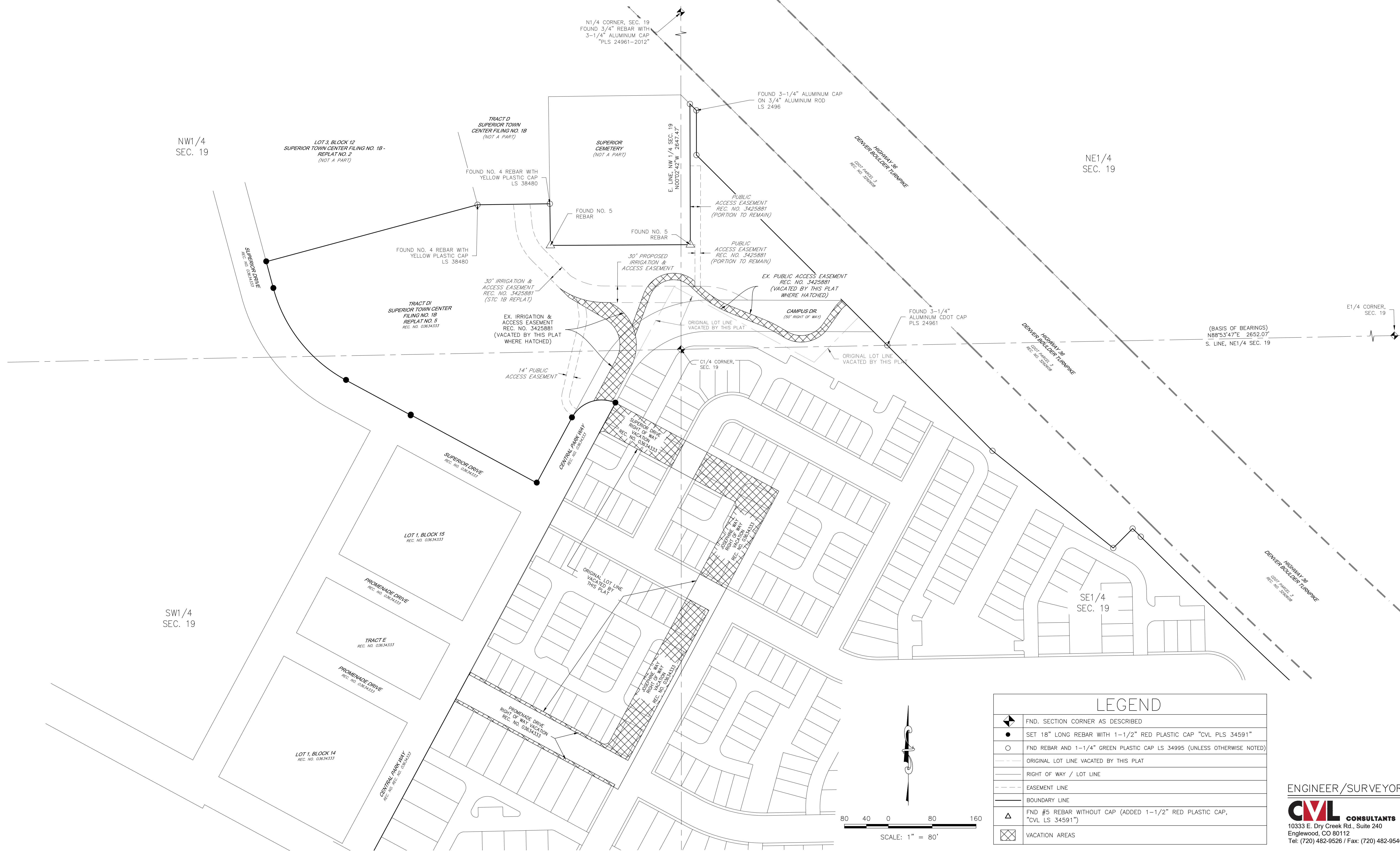

LEGEND	
	FND. SECTION CORNER AS DESCRIBED
	SET 18" LONG REBAR WITH 1-1/2" RED PLASTIC CAP "CVL PLS 34591"
	FND REBAR AND 1-1/4" GREEN PLASTIC CAP LS 34995 (UNLESS OTHERWISE NOTED)
	ORIGINAL LOT LINE VACATED BY THIS PLAT
	RIGHT OF WAY / LOT LINE
	EASEMENT LINE
	BOUNDARY LINE
	FND #5 REBAR WITHOUT CAP (ADDED 1-1/2" RED PLASTIC CAP, "CVL LS 34591")
	VACATION AREAS

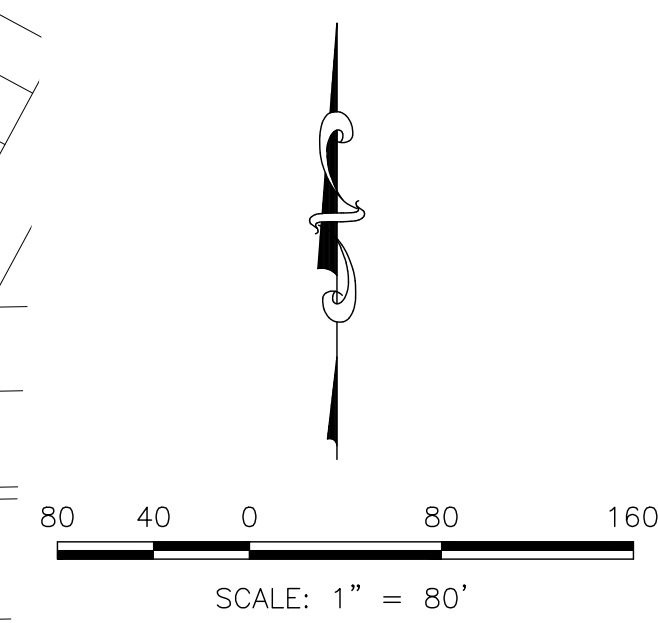

ENGINEER/SURVEYOR
CVL CONSULTANTS
 10333 E. Dry Creek Rd., Suite 240
 Englewood, CO 80112
 Tel: (720) 482-9526 / Fax: (720) 482-9546

PROJECT: SUPERIOR RESIDENTIAL CAD SURVEY FINAL PLAT SUPERIOR - EASEMENT VACATION MAP MICHAEL P. 11/2019

SUPERIOR RESIDENTIAL FILING NO. 1B REPLAT NO. 6 FINAL PLAT

A REPLAT OF LOT 1, BLOCK 17; LOT 1, BLOCK 24; TRACT D1; TRACT H; SUPERLOT 5 AND PORTIONS OF RIGHT OF WAY, SUPERIOR TOWN CENTER FILING NO. 1B, REPLAT NO. 5, AND SUPERLOT 4B, DISCOVERY OFFICE PARK/SUPERIOR TOWN CENTER REPLAT NO. 3 BEING A PART OF SECTION 19, TOWNSHIP 1 SOUTH, RANGE 69 WEST OF THE 6th PRINCIPAL MERIDIAN, TOWN OF SUPERIOR, COUNTY OF BOULDER, STATE OF COLORADO
SHEET 5 OF 12
PLAT SHEETS

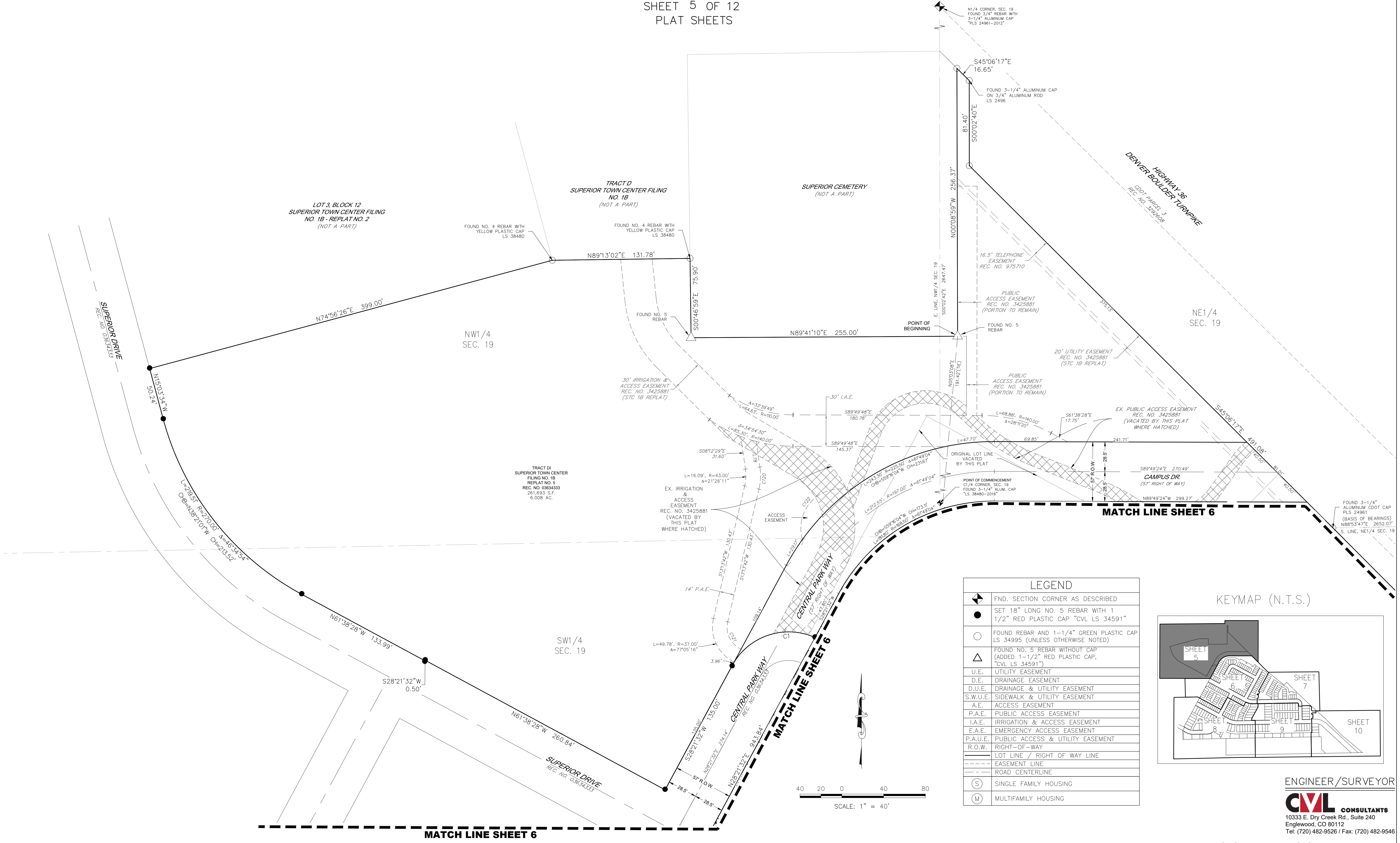

LEGEND	
	FND. SECTION CORNER AS DESCRIBED
	SET 18" LONG NO. 5 REBAR WITH 1 1/2" RED PLASTIC CAP "CVL LS 34591"
	FOUND REBAR AND 1-1/4" GREEN PLASTIC CAP LS 34995 (UNLESS OTHERWISE NOTED)
	FOUND NO. 5 REBAR WITHOUT CAP (ADDED 1-1/2" RED PLASTIC CAP, "CVL LS 34591")
	U.E. UTILITY EASEMENT
	D.E. DRAINAGE EASEMENT
	D.U.E. DRAINAGE & UTILITY EASEMENT
	S.W.U.E. SIDEWALK & UTILITY EASEMENT
	A.E. ACCESS EASEMENT
	P.A.E. PUBLIC ACCESS EASEMENT
	I.A.E. IRRIGATION & ACCESS EASEMENT
	E.A.E. EMERGENCY ACCESS EASEMENT
	P.A.U.E. PUBLIC ACCESS & UTILITY EASEMENT
	R.O.W. RIGHT-OF-WAY
	LOT LINE / RIGHT OF WAY LINE
	EASEMENT LINE
	ROAD CENTERLINE
	S SINGLE FAMILY HOUSING
	M MULTIFAMILY HOUSING

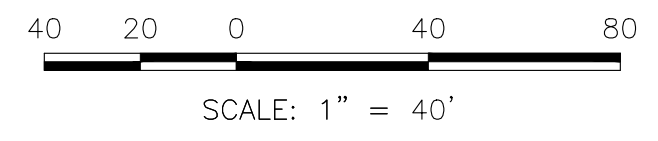
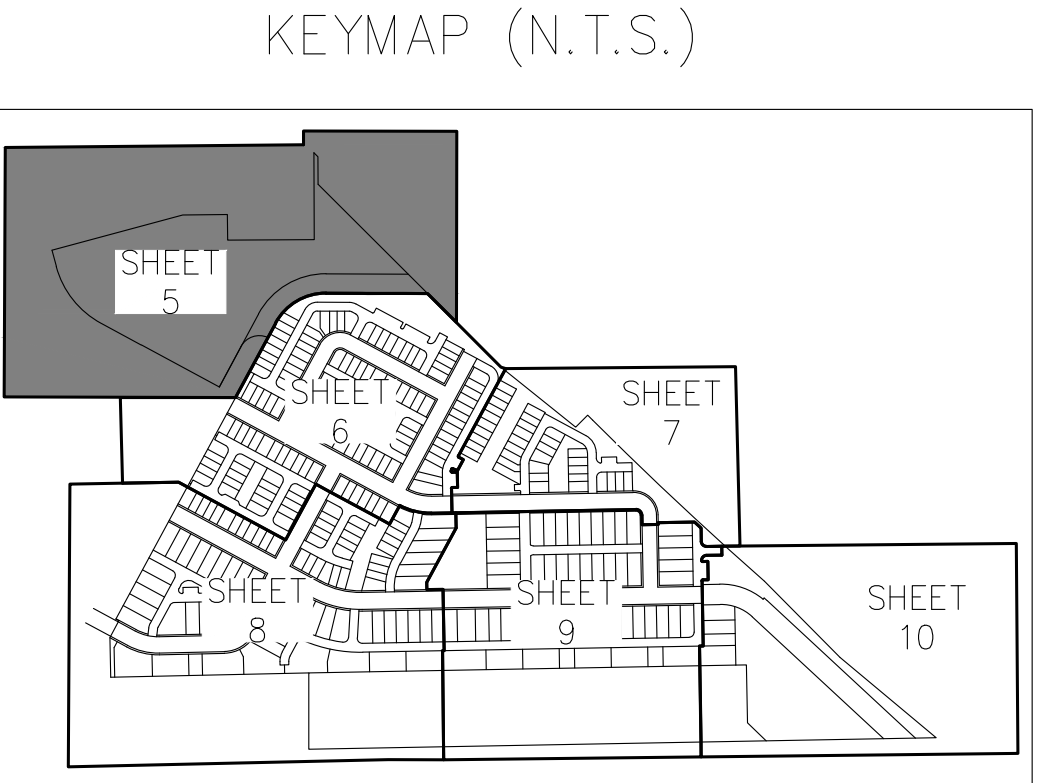

ENGINEER/SURVEYOR
CVL CONSULTANTS
10333 E. Dry Creek Rd., Suite 240
Englewood, CO 80112
Tel: (720) 482-9526 / Fax: (720) 482-9546

SUPERIOR RESIDENTIAL FILING NO. 1B REPLAT NO. 6 FINAL PLAT

A REPLAT OF LOT 1, BLOCK 17; LOT 1, BLOCK 24; TRACT D1; TRACT H; SUPERLOT 5 AND PORTIONS OF RIGHT OF WAY, SUPERIOR TOWN CENTER FILING NO. 1B, REPLAT NO. 5, AND SUPERLOT 4B, DISCOVERY OFFICE PARK/SUPERIOR TOWN CENTER REPLAT NO. 3 BEING A PART OF SECTION 19, TOWNSHIP 1 SOUTH, RANGE 69 WEST OF THE 6th PRINCIPAL MERIDIAN, TOWN OF SUPERIOR, COUNTY OF BOULDER, STATE OF COLORADO
SHEET 6 OF 12
PLAT SHEETS

LEGEND	
	FND. SECTION CORNER AS DESCRIBED
	SET 18" LONG NO. 5 REBAR WITH 1 1/2" RED PLASTIC CAP "CVL LS 34591"
	FOUND REBAR AND 1-1/4" GREEN PLASTIC CAP LS 34995 (UNLESS OTHERWISE NOTED)
	FOUND NO. 5 REBAR WITHOUT CAP (ADDED 1-1/2" RED PLASTIC CAP, "CVL LS 34591")
	U.E. UTILITY EASEMENT
	D.E. DRAINAGE EASEMENT
	D.U.E. DRAINAGE & UTILITY EASEMENT
	S.W.U.E. SIDEWALK & UTILITY EASEMENT
	A.E. ACCESS EASEMENT
	P.A.E. PUBLIC ACCESS EASEMENT
	I.A.E. IRRIGATION & ACCESS EASEMENT
	E.A.E. EMERGENCY ACCESS EASEMENT
	P.A.U.E. PUBLIC ACCESS & UTILITY EASEMENT
	R.O.W. RIGHT-OF-WAY
	LOT LINE / RIGHT OF WAY LINE
	EASEMENT LINE
	ROAD CENTERLINE
	SINGLE FAMILY HOUSING
	MULTIFAMILY HOUSING
	RIGHT OF WAY VACATED BY THIS PLAT

KEYMAP (N.T.S.)

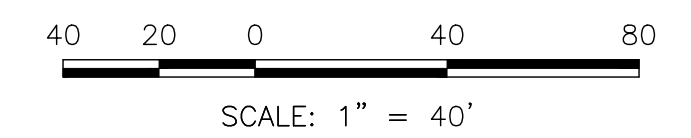
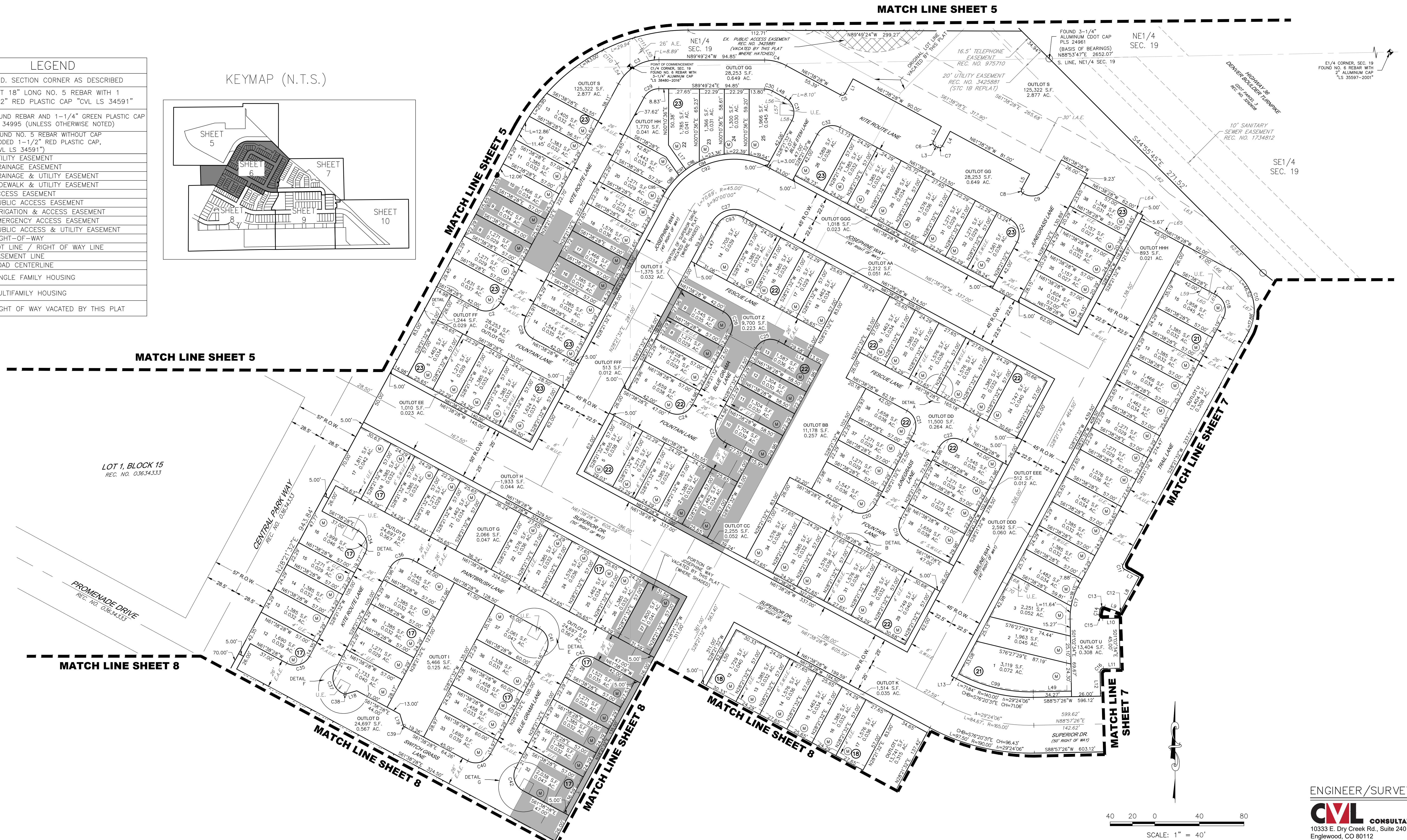
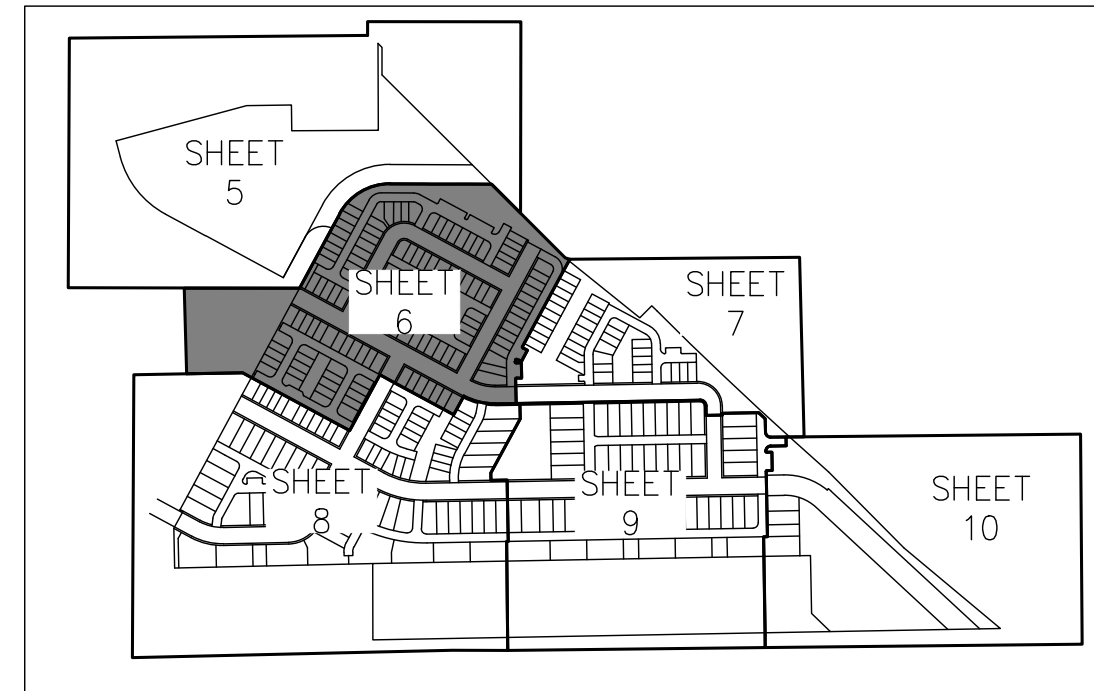

ENGINEER/SURVEYOR

CVL CONSULTANTS
10333 E. Dry Creek Rd., Suite 240
Englewood, CO 80112
Tel: (720) 482-9526 / Fax: (720) 482-9546

SUPERIOR RESIDENTIAL FILING NO. 1B REPLAT NO. 6 FINAL PLAT

A REPLAT OF LOT 1, BLOCK 17; LOT 1, BLOCK 24; TRACT D1; TRACT H; SUPERLOT 5 AND PORTIONS OF RIGHT OF WAY, SUPERIOR TOWN CENTER FILING NO. 1B, REPLAT NO. 5, AND SUPERLOT 4B, DISCOVERY OFFICE PARK/SUPERIOR TOWN CENTER REPLAT NO. 3 BEING A PART OF SECTION 19, TOWNSHIP 1 SOUTH, RANGE 69 WEST OF THE 6th PRINCIPAL MERIDIAN, TOWN OF SUPERIOR, COUNTY OF BOULDER, STATE OF COLORADO
SHEET 7 OF 12
PLAT SHEETS

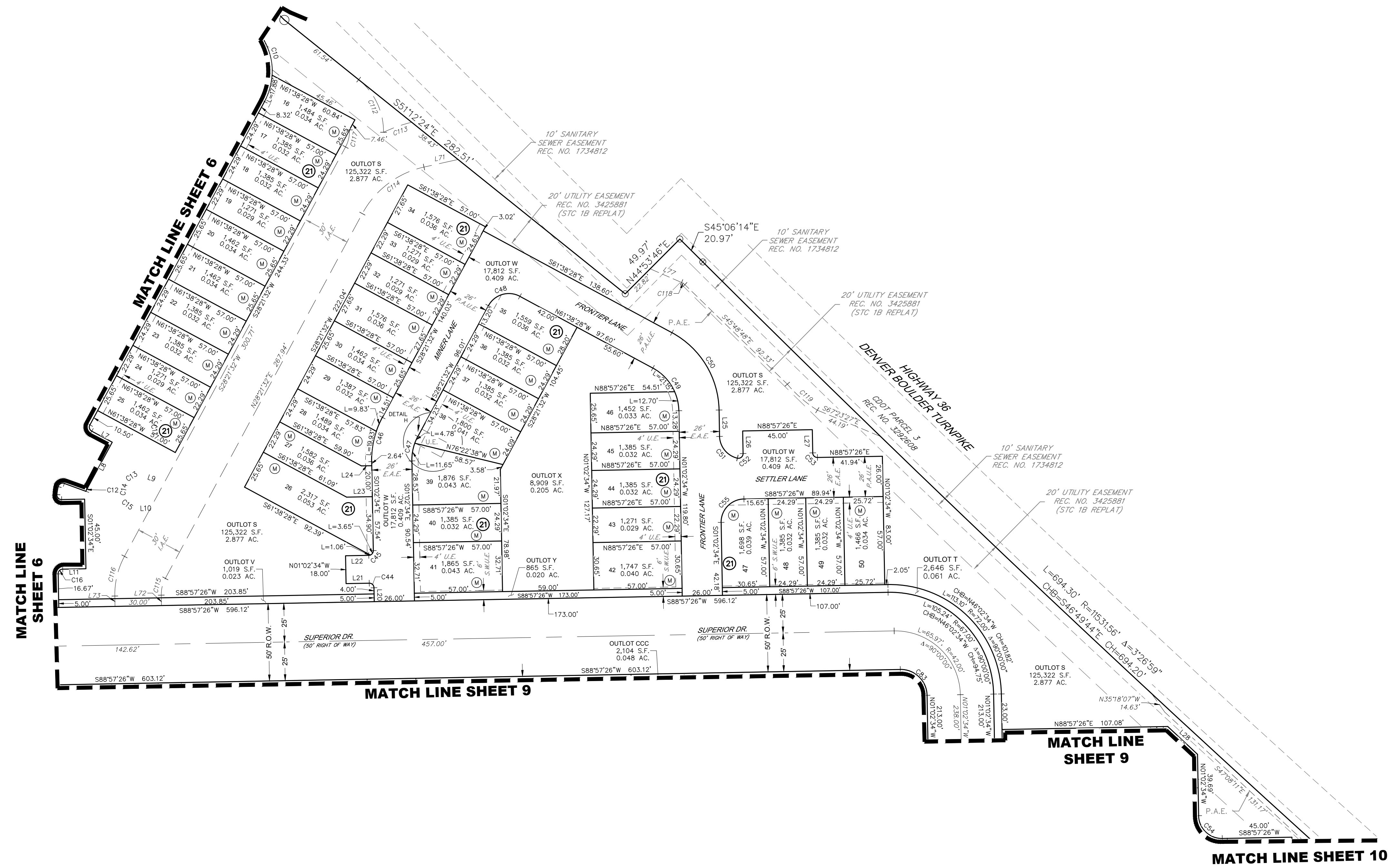

KEYMAP (N.T.S.)

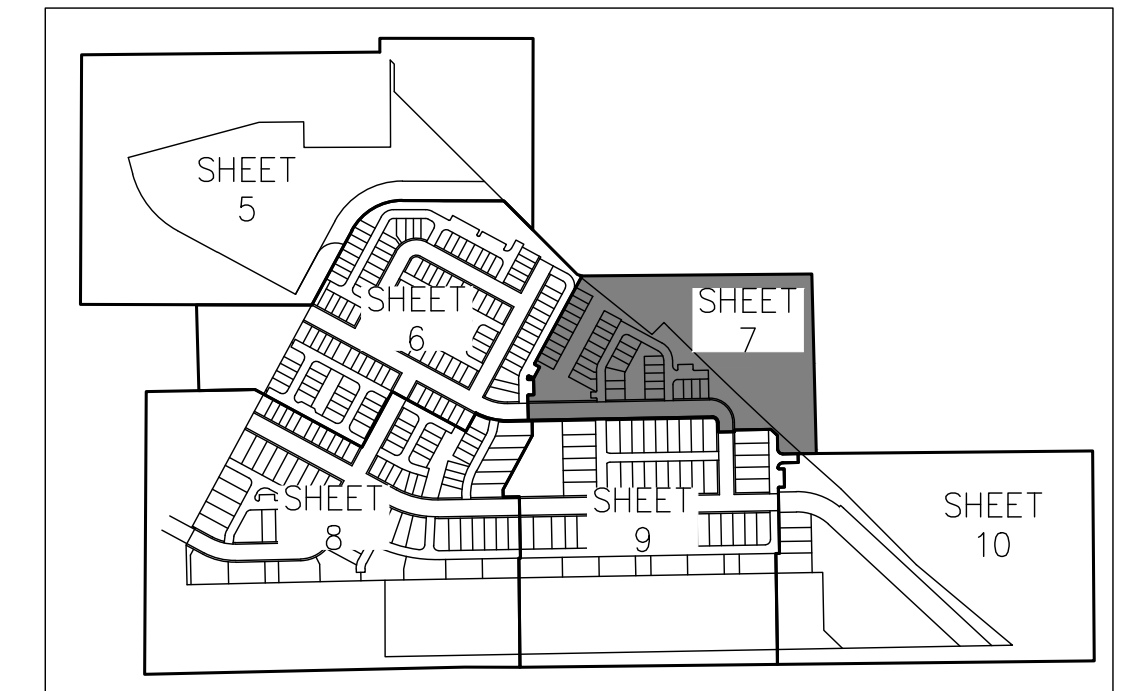

LEGEND	
	FND. SECTION CORNER AS DESCRIBED
	SET 18" LONG NO. 5 REBAR WITH 1 1/2" RED PLASTIC CAP "CVL LS 34591"
	FOUND NO. 5 REBAR WITHOUT CAP (ADDED 1-1/2" RED PLASTIC CAP, "CVL LS 34591")
	U.E. UTILITY EASEMENT
	D.E. DRAINAGE EASEMENT
	D.U.E. DRAINAGE & UTILITY EASEMENT
	S.W.U.E. SIDEWALK & UTILITY EASEMENT
	A.E. ACCESS EASEMENT
	P.A.E. PUBLIC ACCESS EASEMENT
	I.A.E. IRRIGATION & ACCESS EASEMENT
	E.A.E. EMERGENCY ACCESS EASEMENT
	P.A.U.E. PUBLIC ACCESS & UTILITY EASEMENT
	R.O.W. RIGHT-OF-WAY
	LOT LINE / RIGHT OF WAY LINE
	EASEMENT LINE
	ROAD CENTERLINE
	(S) SINGLE FAMILY HOUSING
	(M) MULTIFAMILY HOUSING

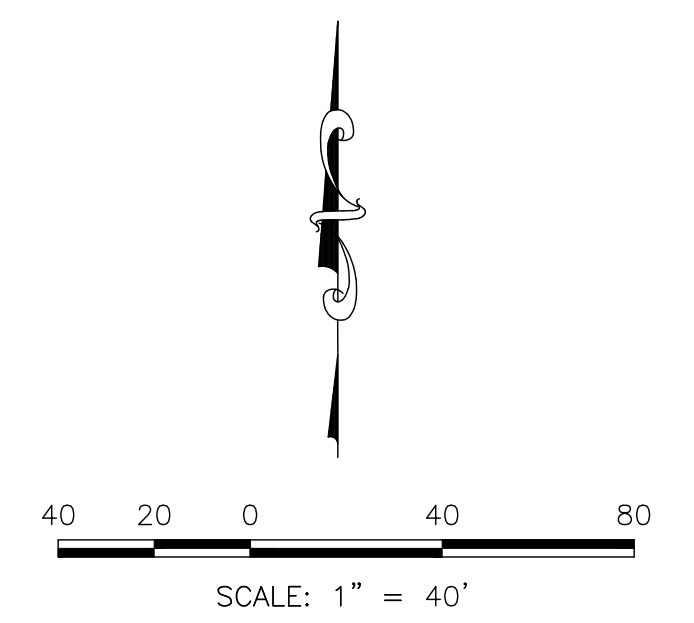

PROJECT: SUPERIOR RESIDENTIAL CAD SURVEY FINAL PLAT SUPERIOR - PLAT SHEETS DWG: MICHAEL.P. 1/2019

ENGINEER/SURVEYOR
CVL CONSULTANTS
10333 E. Dry Creek Rd., Suite 240
Englewood, CO 80112
Tel: (720) 482-9526 / Fax: (720) 482-9546

SUPERIOR RESIDENTIAL FILING NO. 1B REPLAT NO. 6 FINAL PLAT

A REPLAT OF LOT 1, BLOCK 17; LOT 1, BLOCK 24; TRACT D1; TRACT H; SUPERLOT 5 AND PORTIONS OF RIGHT OF WAY, SUPERIOR TOWN CENTER FILING NO. 1B, REPLAT NO. 5, AND SUPERLOT 4B, DISCOVERY OFFICE PARK/SUPERIOR TOWN CENTER REPLAT NO. 3 BEING A PART OF SECTION 19, TOWNSHIP 1 SOUTH, RANGE 69 WEST OF THE 6th PRINCIPAL MERIDIAN, TOWN OF SUPERIOR, COUNTY OF BOULDER, STATE OF COLORADO

SHEET 8 OF 12
PLAT SHEETS

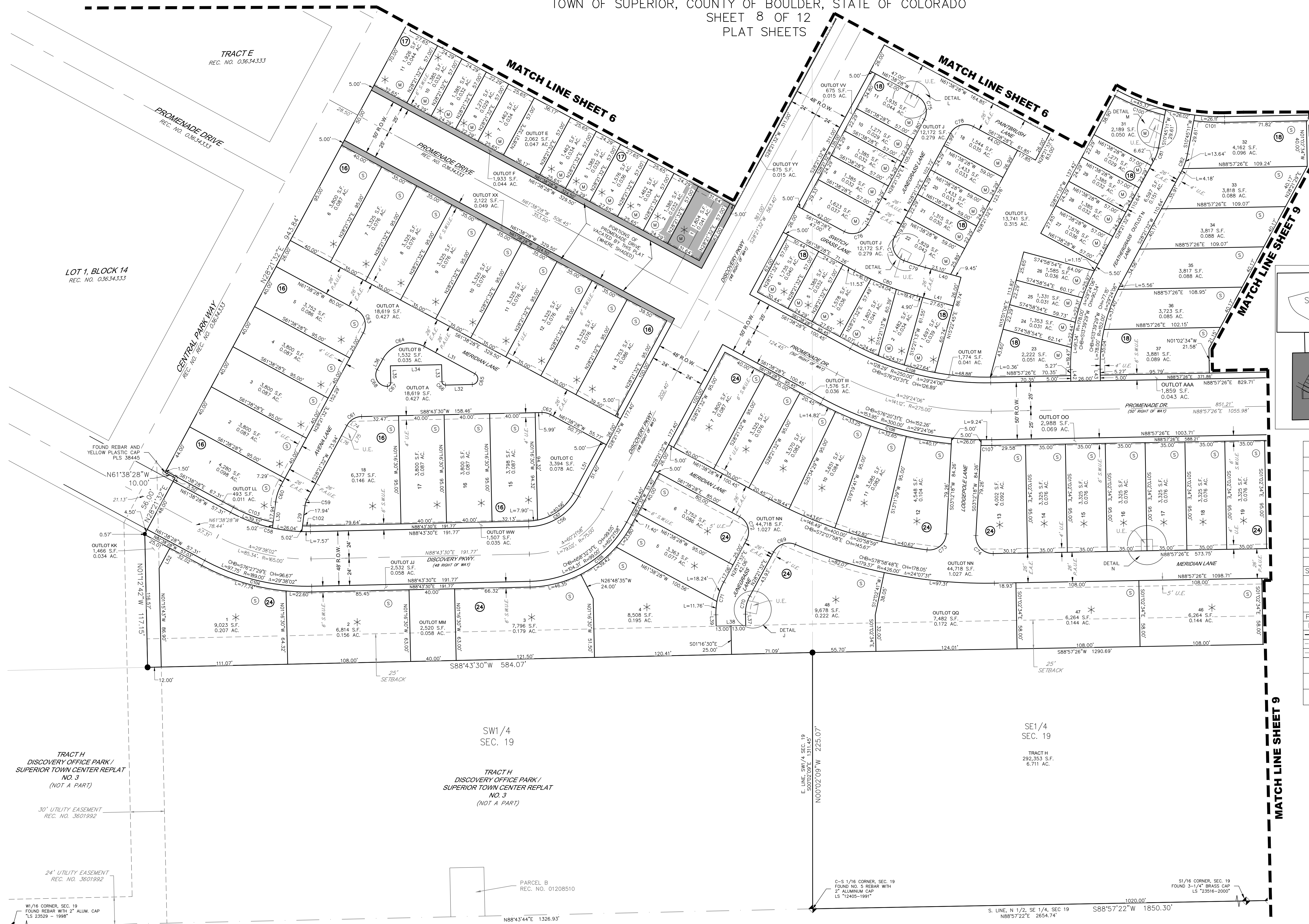

KEYMAP (N.T.S.)

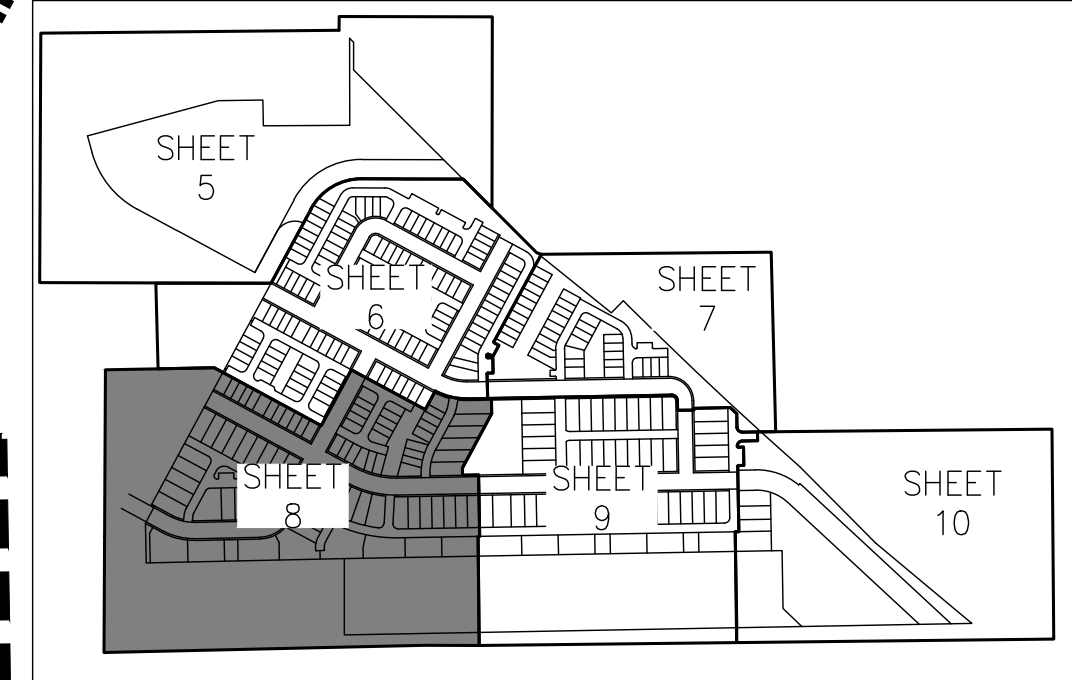

LEGEND	
	FND. SECTION CORNER AS DESCRIBED
	SET 1/2" LONG NO. 5 REBAR WITH 1 1/2" RED PLASTIC CAP "CVL LS 34591"
	FOUND REBAR AND 1-1/4" GREEN PLASTIC CAP LS 34995 (UNLESS OTHERWISE NOTED)
	FOUND NO. 5 REBAR WITHOUT CAP (ADDED 1-1/2" RED PLASTIC CAP, "CVL LS 34591")
	U.E. UTILITY EASEMENT
	D.E. DRAINAGE EASEMENT
	D.U.E. DRAINAGE & UTILITY EASEMENT
	S.W.U.E. SIDEWALK & UTILITY EASEMENT
	A.E. ACCESS EASEMENT
	P.A.E. PUBLIC ACCESS EASEMENT
	I.A.E. IRRIGATION & ACCESS EASEMENT
	E.A.E. EMERGENCY ACCESS EASEMENT
	P.A.U.E. PUBLIC ACCESS & UTILITY EASEMENT
	R.O.W. RIGHT-OF-WAY
	LOT LINE / RIGHT OF WAY LINE
	EASEMENT LINE
	ROAD CENTERLINE
	(S) SINGLE FAMILY HOUSING
	(M) MULTIFAMILY HOUSING
	LOT WITHIN VIEW SENSITIVE AREA (VSA), SUBJECT TO (VSA) ANALYSIS FOR BUILDING PERMITS.

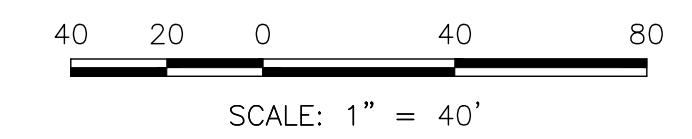

ENGINEER/SURVEYOR

CVL CONSULTANTS
10333 E. Dry Creek Rd., Suite 240
Englewood, CO 80112
Tel: (720) 482-9526 / Fax: (720) 482-9546

SUPERIOR RESIDENTIAL FILING NO. 1B REPLAT NO. 6 FINAL PLAT

A REPLAT OF LOT 1, BLOCK 17; LOT 1, BLOCK 24; TRACT D1; TRACT H; SUPERLOT 5 AND PORTIONS OF RIGHT OF WAY, SUPERIOR TOWN CENTER FILING NO. 1B, REPLAT NO. 5, AND SUPERLOT 4B, DISCOVERY OFFICE PARK/SUPERIOR TOWN CENTER REPLAT NO. 3 BEING A PART OF SECTION 19, TOWNSHIP 1 SOUTH, RANGE 69 WEST OF THE 6th PRINCIPAL MERIDIAN, TOWN OF SUPERIOR, COUNTY OF BOULDER, STATE OF COLORADO
SHEET 9 OF 12
PLAT SHEETS

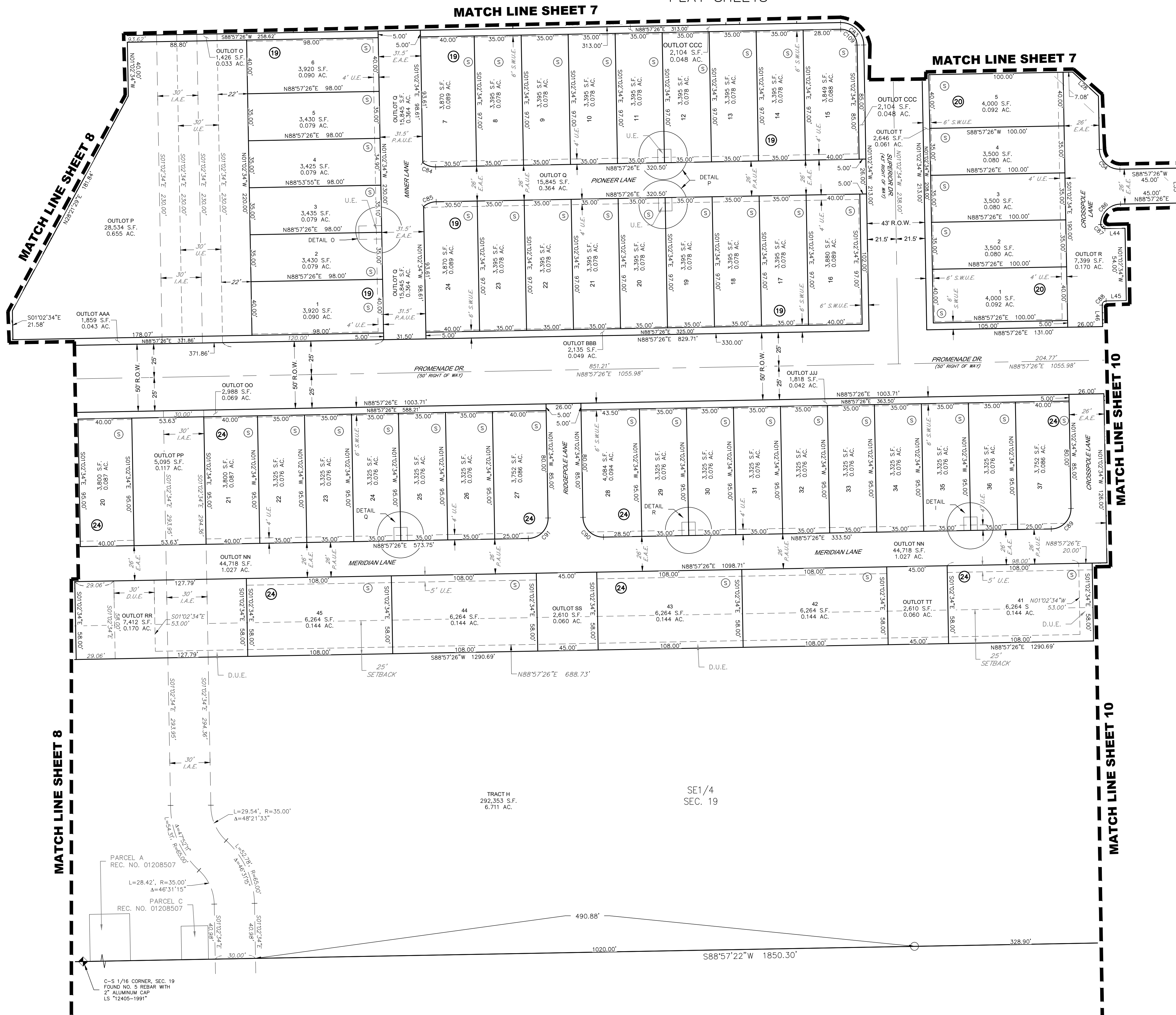

KEYMAP (N.T.S.)

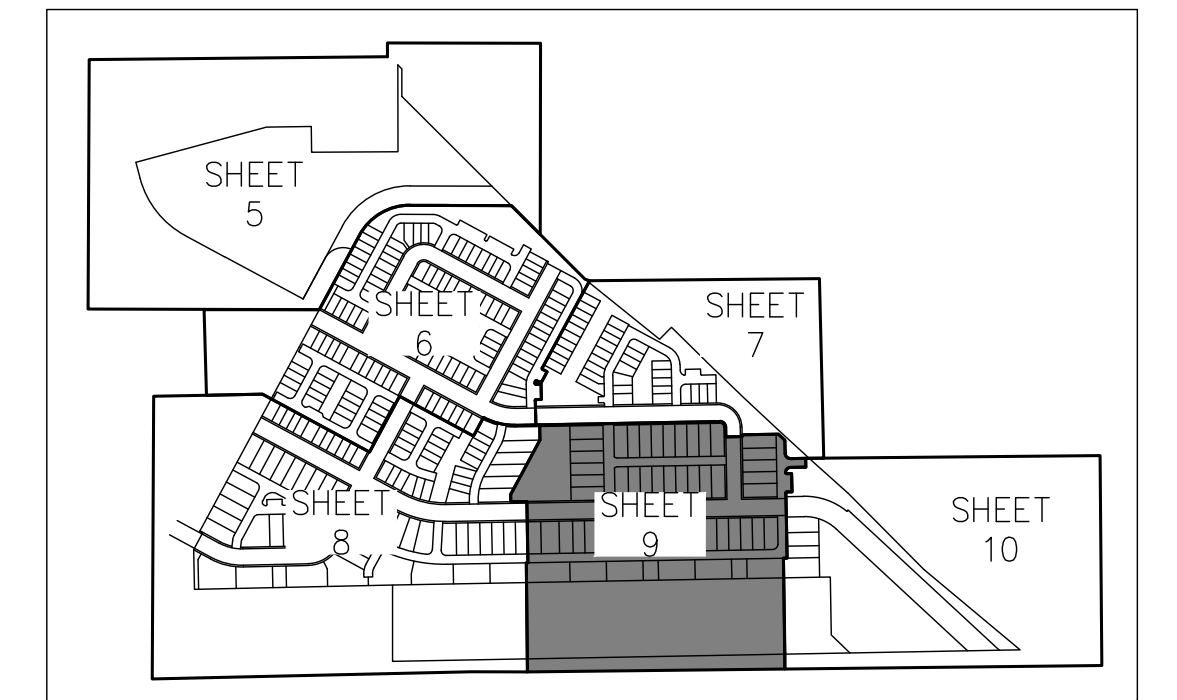

LEGEND	
	FND. SECTION CORNER AS DESCRIBED
	SET 18" LONG NO. 5 REBAR WITH 1 1/2" RED PLASTIC CAP "CVL LS 34591"
	FOUND REBAR AND 1-1/4" GREEN PLASTIC CAP LS 34995 (UNLESS OTHERWISE NOTED)
	FOUND NO. 5 REBAR WITHOUT CAP (ADDED 1-1/2" RED PLASTIC CAP, "CVL LS 34591")
	U.E. UTILITY EASEMENT
	D.E. DRAINAGE EASEMENT
	D.U.E. DRAINAGE & UTILITY EASEMENT
	S.W.U.E. SIDEWALK & UTILITY EASEMENT
	A.E. ACCESS EASEMENT
	P.A.E. PUBLIC ACCESS EASEMENT
	I.A.E. IRRIGATION & ACCESS EASEMENT
	E.A.E. EMERGENCY ACCESS EASEMENT
	P.A.U.E. PUBLIC ACCESS & UTILITY EASEMENT
	R.O.W. RIGHT-OF-WAY
	LOT LINE / RIGHT OF WAY LINE
	EASEMENT LINE
	ROAD CENTERLINE
	(S) SINGLE FAMILY HOUSING
	(M) MULTIFAMILY HOUSING

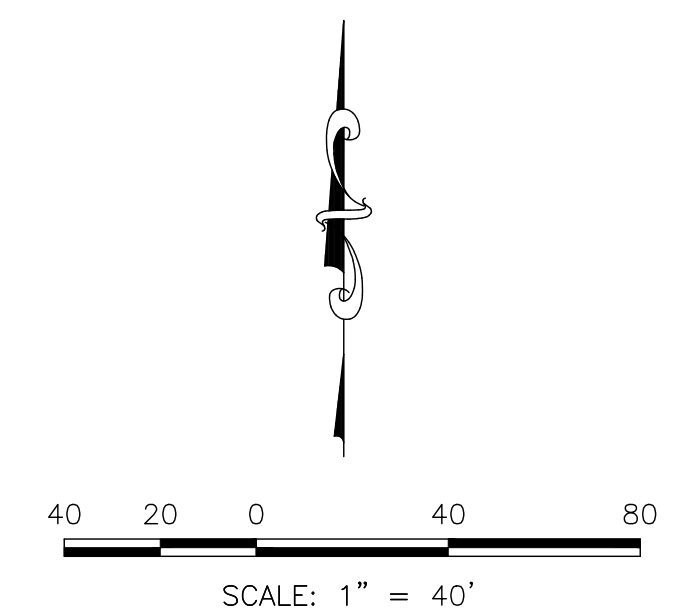

PROJECT: SUPERIOR RESIDENTIAL CAD SURVEY FINAL PLAT SUPERIOR - PLAT SHEET DWG: MICHAEL P. 10219

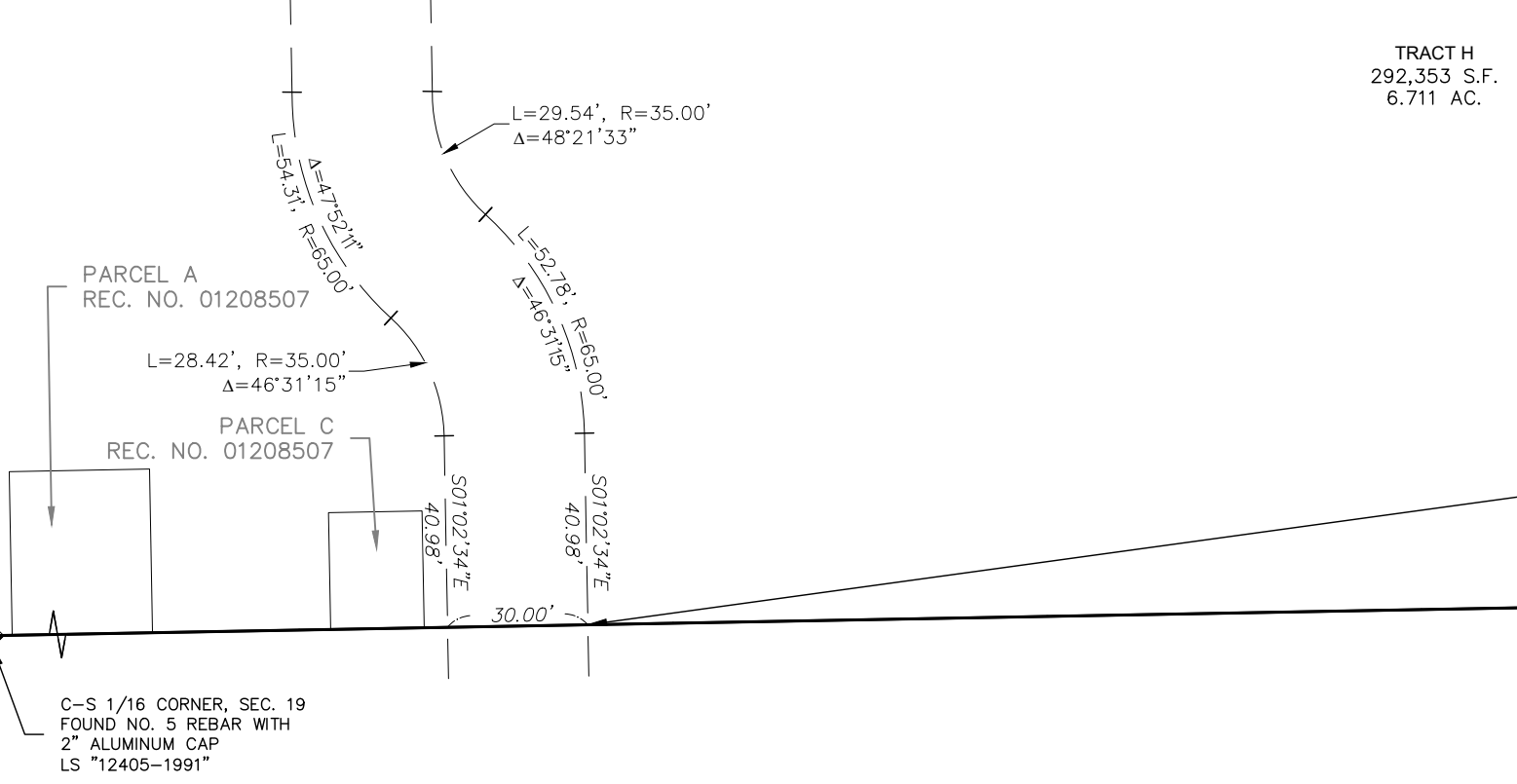

SUPERIOR RESIDENTIAL FILING NO. 1B REPLAT NO. 6 FINAL PLAT

A REPLAT OF LOT 1, BLOCK 17; LOT 1, BLOCK 24; TRACT D1; TRACT H; SUPERLOT 5 AND PORTIONS OF RIGHT OF WAY, SUPERIOR TOWN CENTER FILING NO. 1B, REPLAT NO. 5, AND SUPERLOT 4B, DISCOVERY OFFICE PARK/SUPERIOR TOWN CENTER REPLAT NO. 3 BEING A PART OF SECTION 19, TOWNSHIP 1 SOUTH, RANGE 69 WEST OF THE 6th PRINCIPAL MERIDIAN, TOWN OF SUPERIOR, COUNTY OF BOULDER, STATE OF COLORADO
SHEET 10 OF 12
PLAT SHEETS

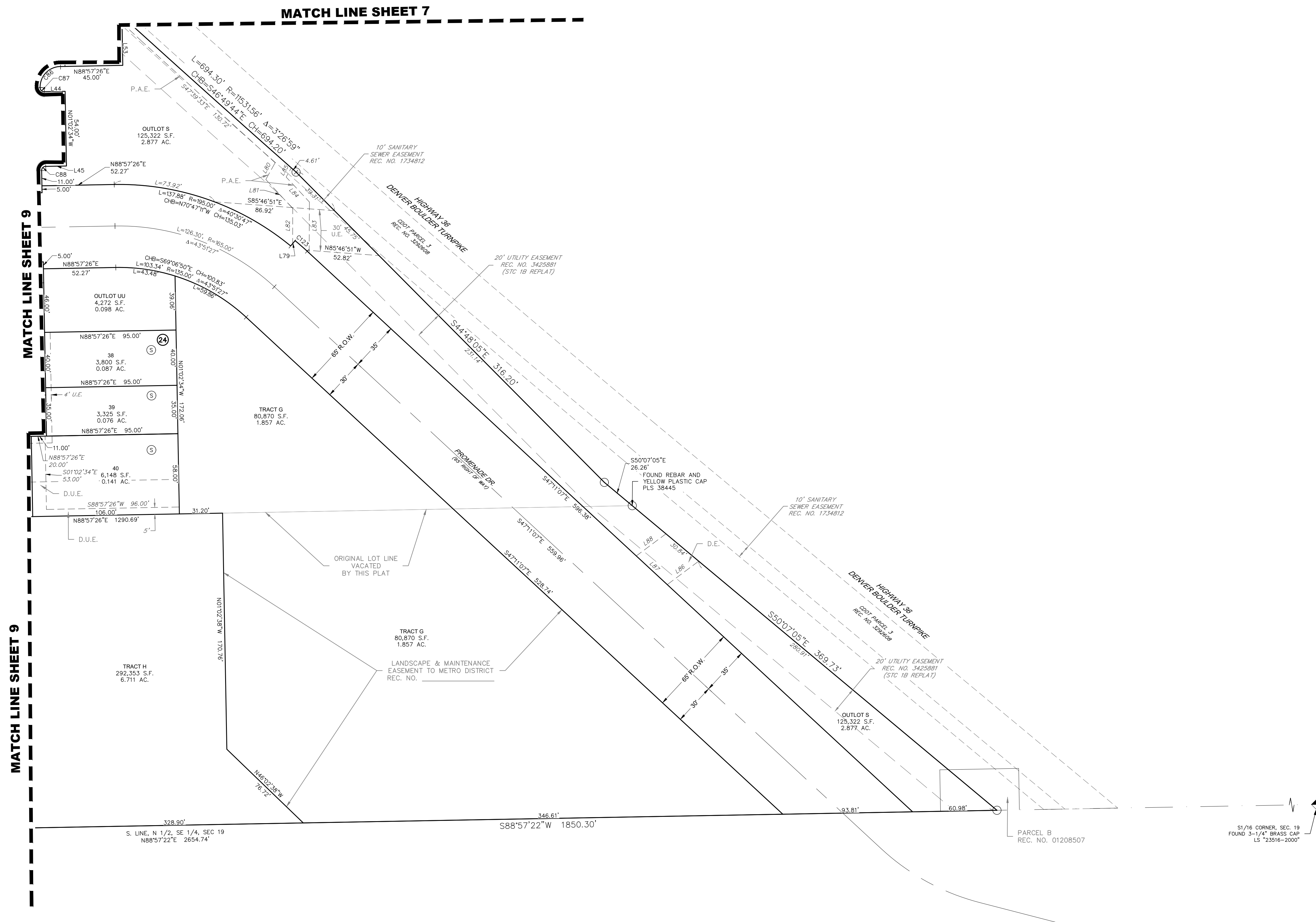

KEYMAP (N.T.S.)

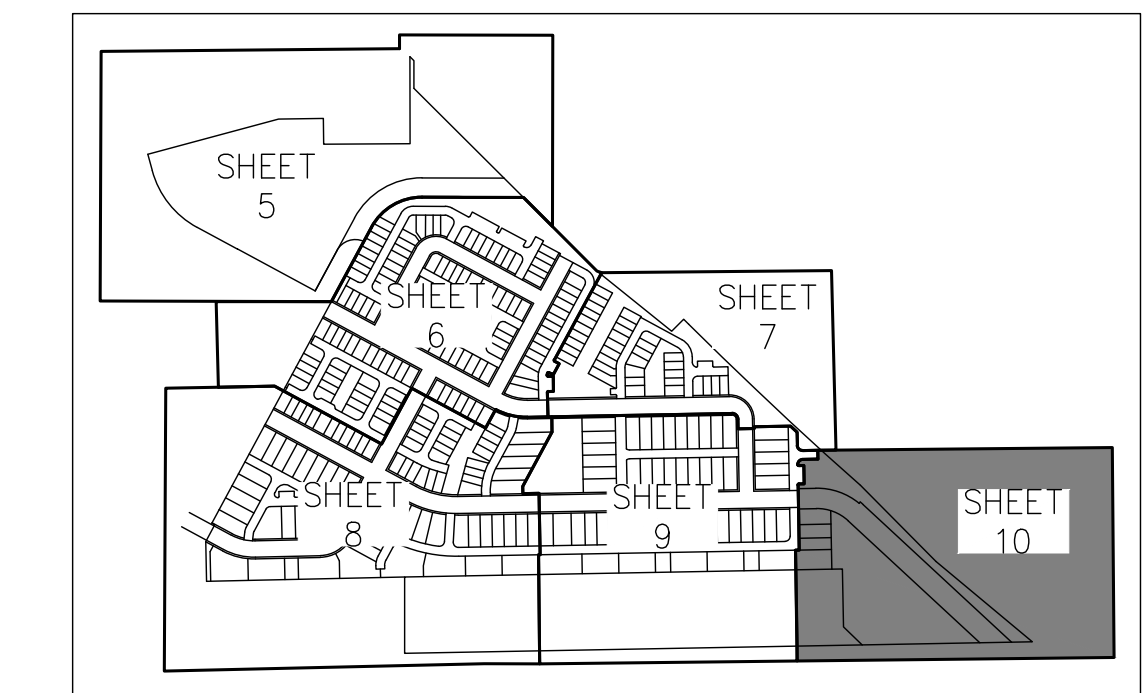

LEGEND	
◆	FND. SECTION CORNER AS DESCRIBED
●	SET 18" LONG NO. 5 REBAR WITH 1 1/2" RED PLASTIC CAP "CVL LS 34591"
○	FOUND REBAR AND 1-1/4" GREEN PLASTIC CAP LS 34995 (UNLESS OTHERWISE NOTED)
△	FOUND NO. 5 REBAR WITHOUT CAP (ADDED 1-1/2" RED PLASTIC CAP, "CVL LS 34591")
U.E.	UTILITY EASEMENT
D.E.	DRAINAGE EASEMENT
D.U.E.	DRAINAGE & UTILITY EASEMENT
S.W.U.E.	SIDEWALK & UTILITY EASEMENT
A.E.	ACCESS EASEMENT
P.A.E.	PUBLIC ACCESS EASEMENT
I.A.E.	IRRIGATION & ACCESS EASEMENT
E.A.E.	EMERGENCY ACCESS EASEMENT
P.A.U.E.	PUBLIC ACCESS & UTILITY EASEMENT
R.O.W.	RIGHT-OF-WAY
---	LOT LINE / RIGHT OF WAY LINE
----	EASEMENT LINE
- - - -	ROAD CENTERLINE
(S)	SINGLE FAMILY HOUSING
(M)	MULTIFAMILY HOUSING

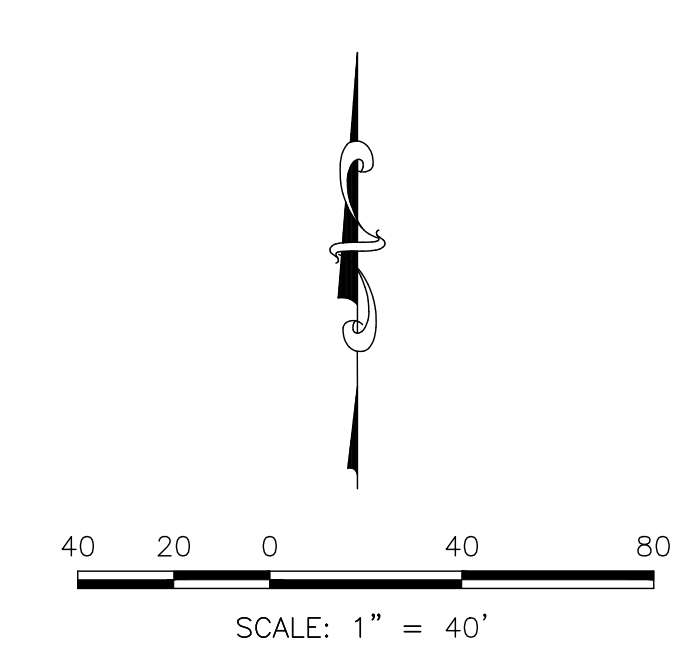

PROJECT: SUPERIOR RESIDENTIAL CAD SURVEY FINAL PLAT SUPERIOR - PLAT SHEETS DWG: MICHAEL.P. 1/2019

ENGINEER/SURVEYOR
CVL CONSULTANTS
10333 E. Dry Creek Rd., Suite 240
Englewood, CO 80112
Tel: (720) 482-9526 / Fax: (720) 482-9546

SUPERIOR RESIDENTIAL FILING NO. 1B REPLAT NO. 6 FINAL PLAT

A REPLAT OF LOT 1, BLOCK 17; LOT 1, BLOCK 24; TRACT D1; TRACT H; SUPERLOT 5 AND PORTIONS OF RIGHT OF WAY, SUPERIOR TOWN CENTER FILING NO. 1B, REPLAT NO. 5, AND SUPERLOT 4B, DISCOVERY OFFICE PARK/SUPERIOR TOWN CENTER REPLAT NO. 3 BEING A PART OF SECTION 19, TOWNSHIP 1 SOUTH, RANGE 69 WEST OF THE 6th PRINCIPAL MERIDIAN, TOWN OF SUPERIOR, COUNTY OF BOULDER, STATE OF COLORADO
SHEET 11 OF 12

PLAT EASEMENT DETAILS

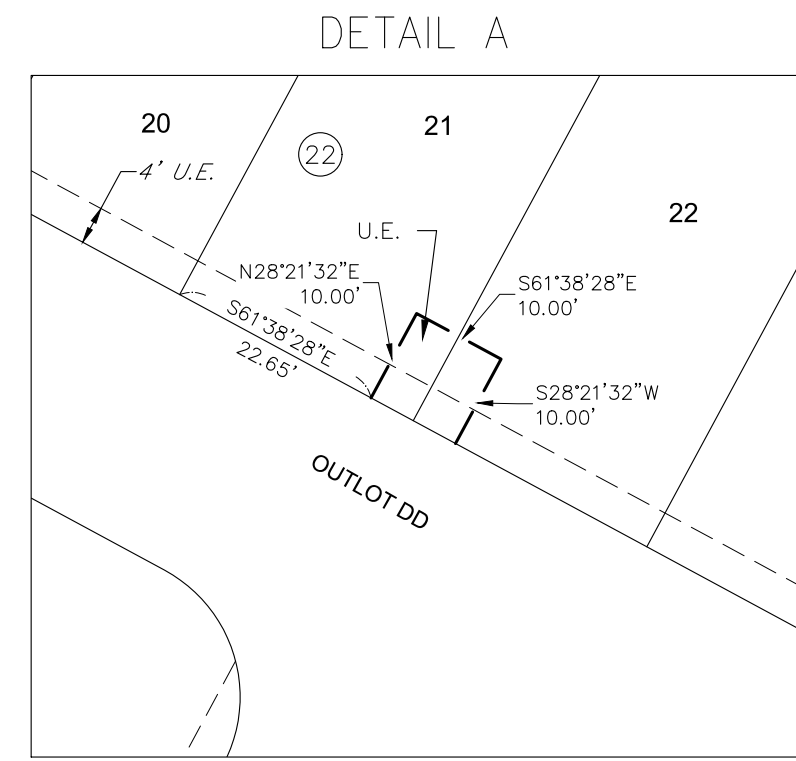

SCALE: 1" = 20'

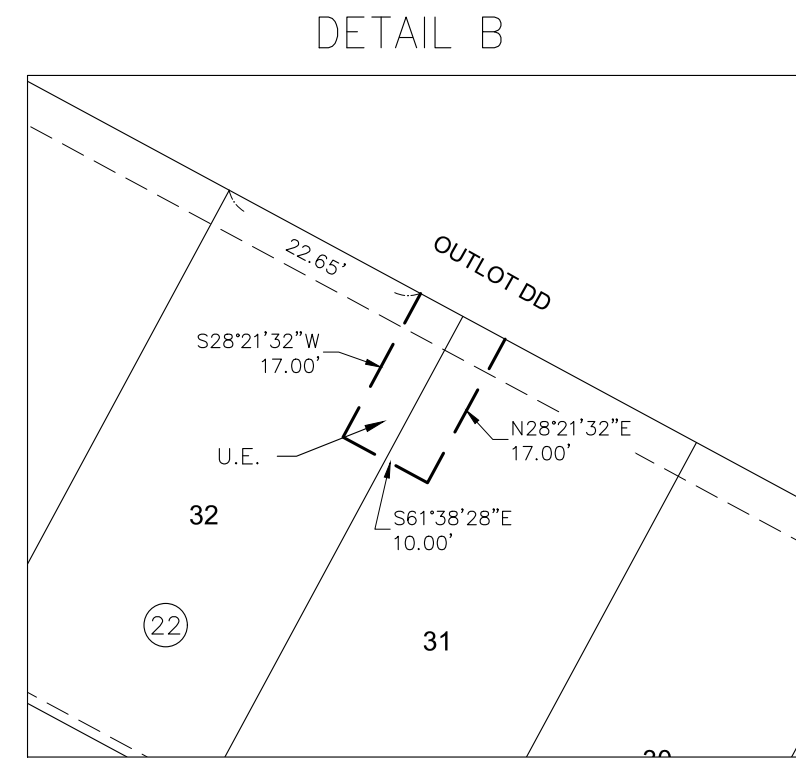

SCALE: 1" = 20'

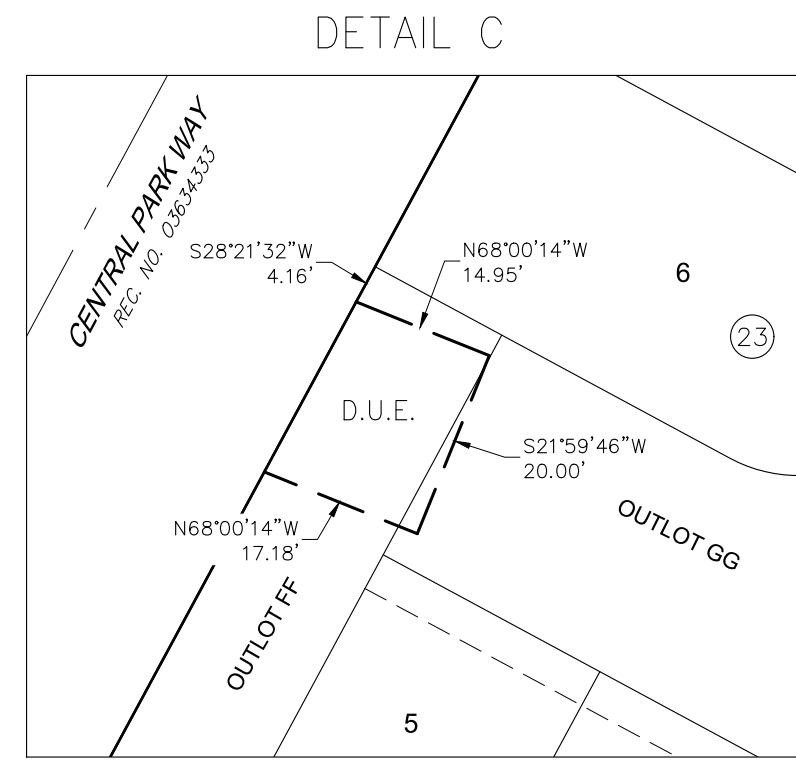

SCALE: 1" = 20'

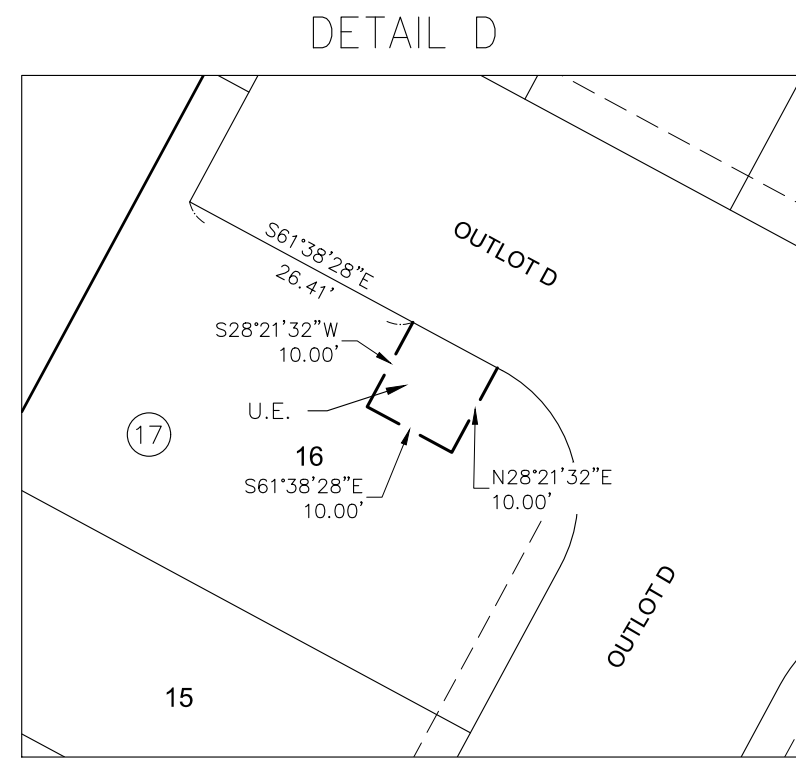

SCALE: 1" = 20'

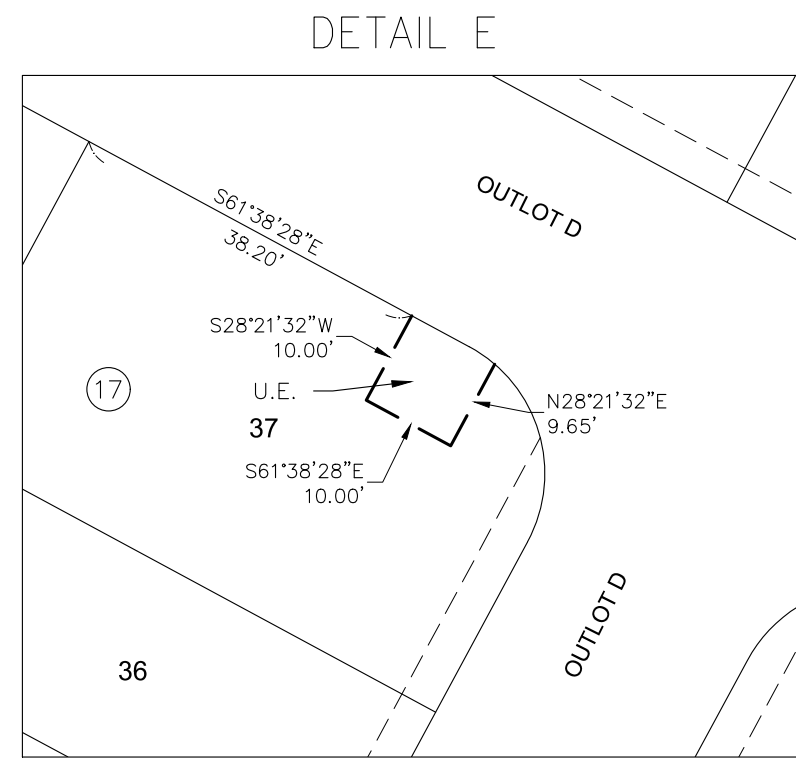

SCALE: 1" = 20'

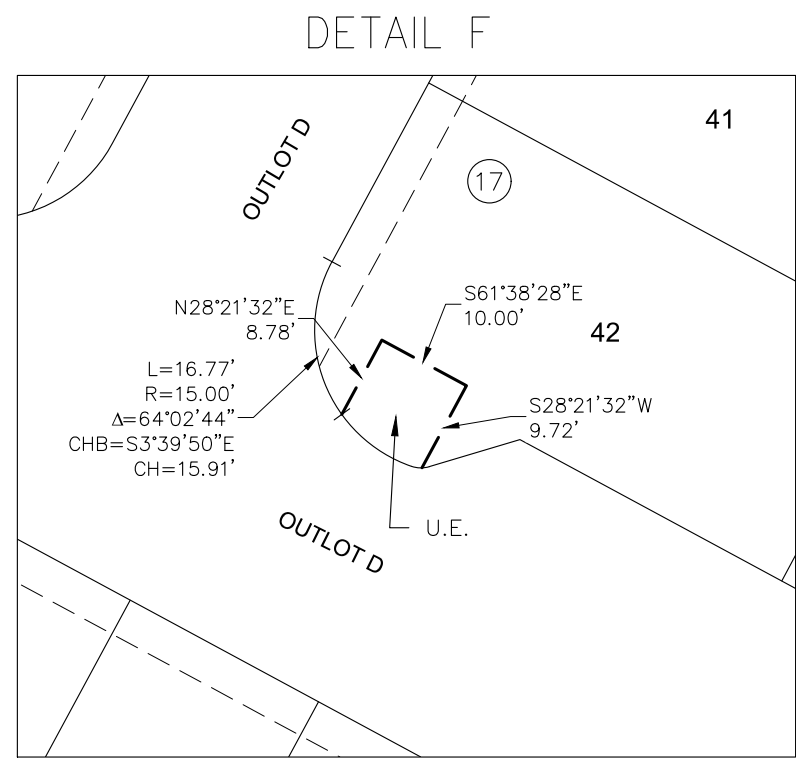

SCALE: 1" = 20'

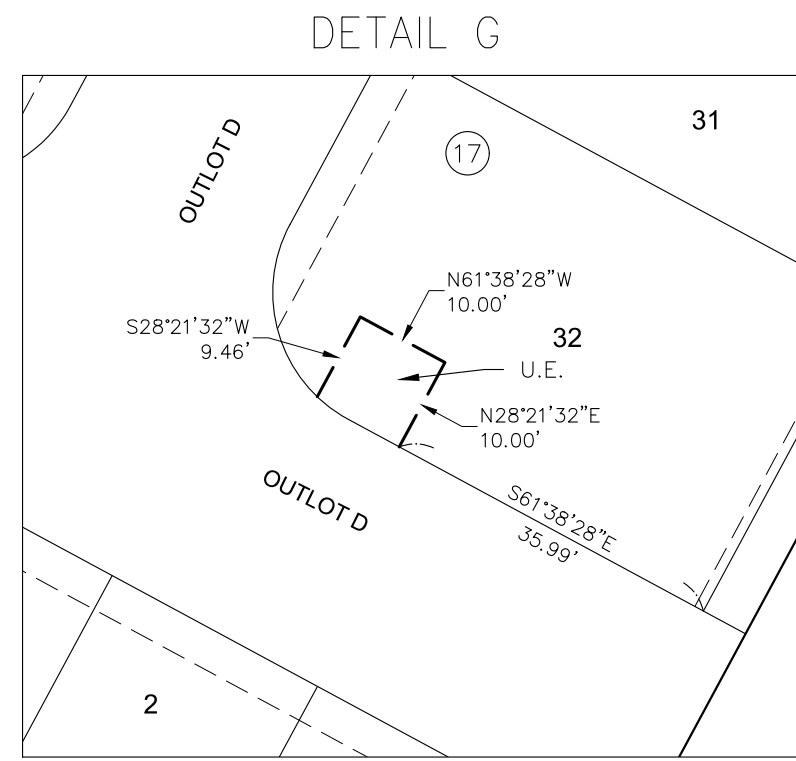

SCALE: 1" = 20'

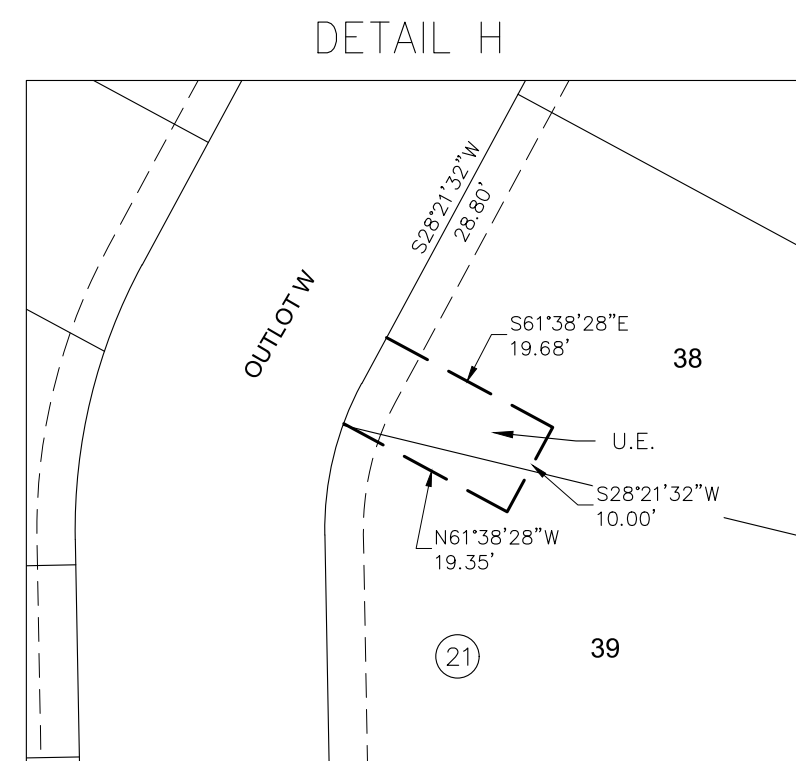

SCALE: 1" = 20'

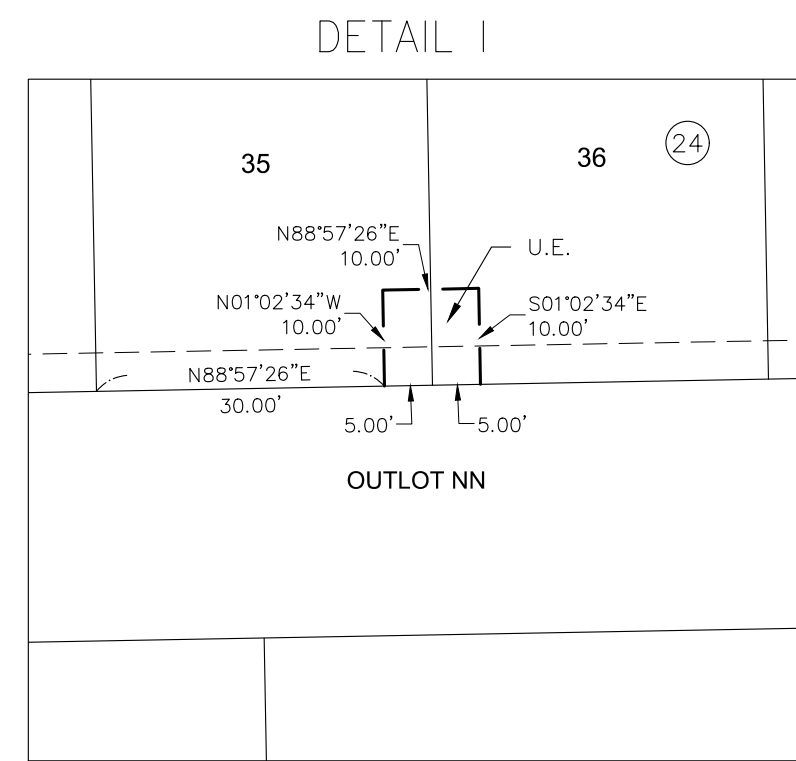

SCALE: 1" = 20'

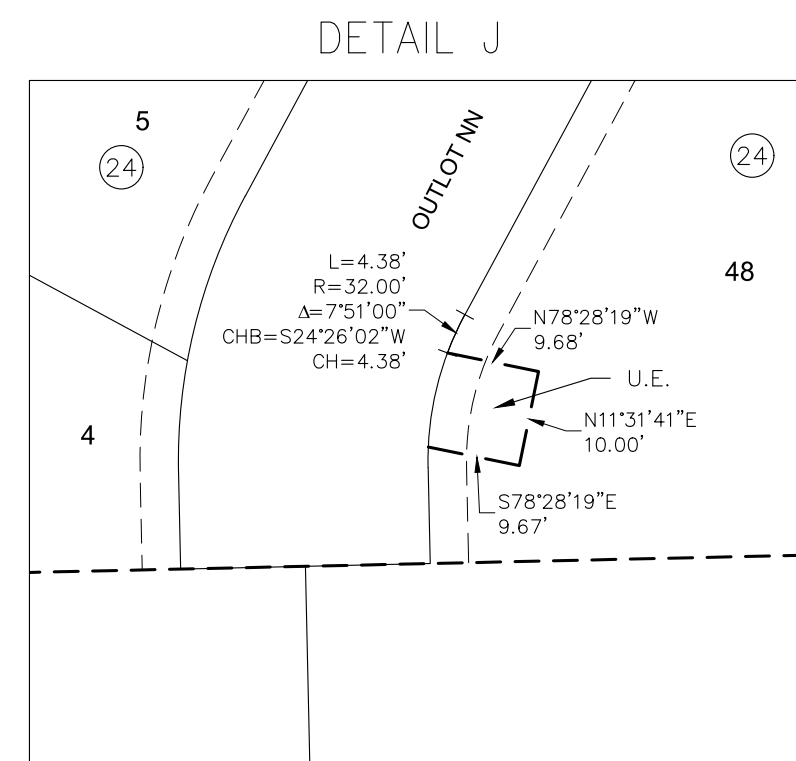

SCALE: 1" = 20'

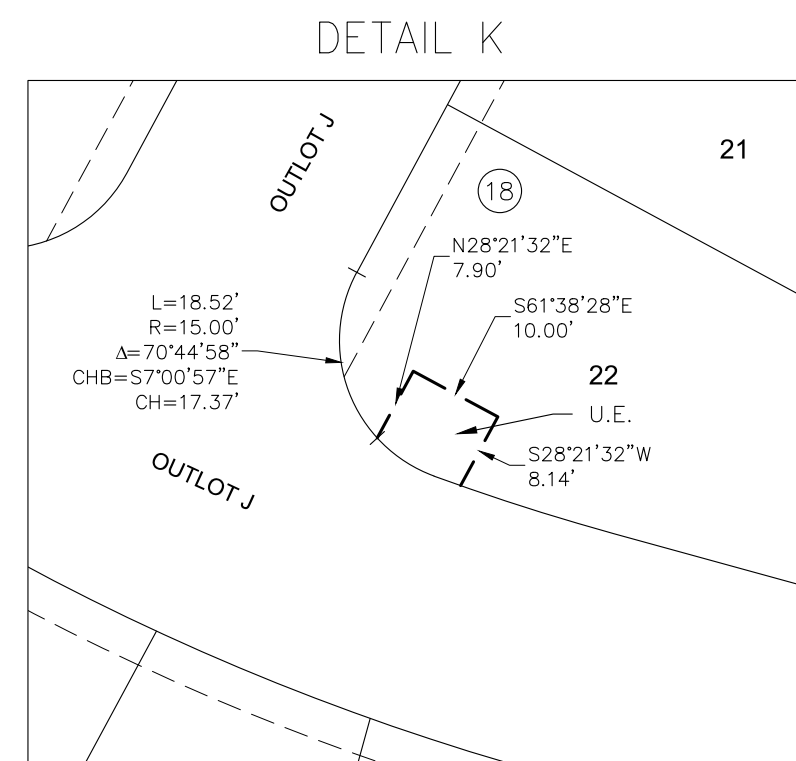

SCALE: 1" = 20'

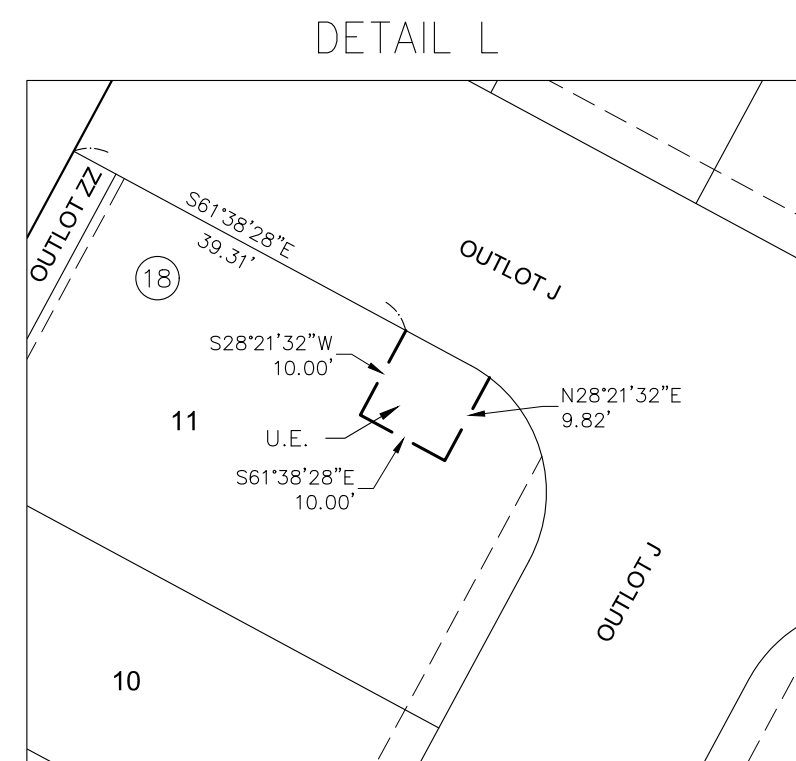

SCALE: 1" = 20'

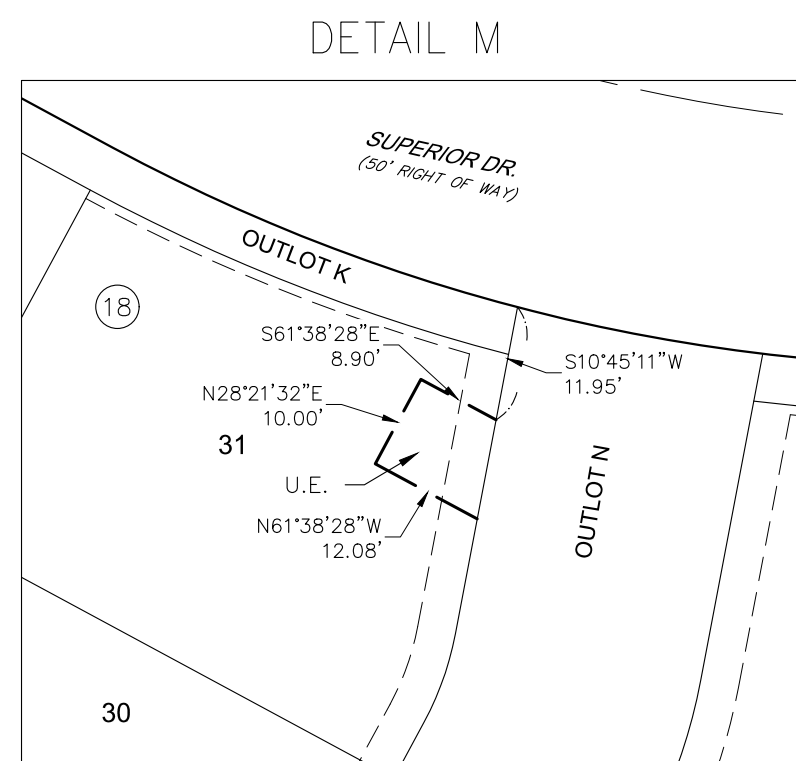

SCALE: 1" = 20'

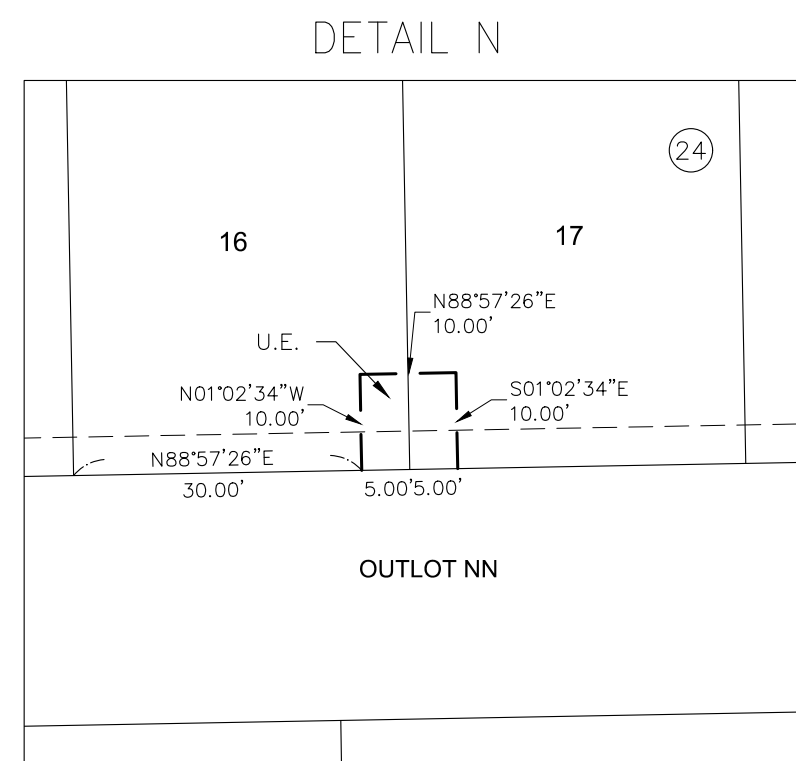

SCALE: 1" = 20'

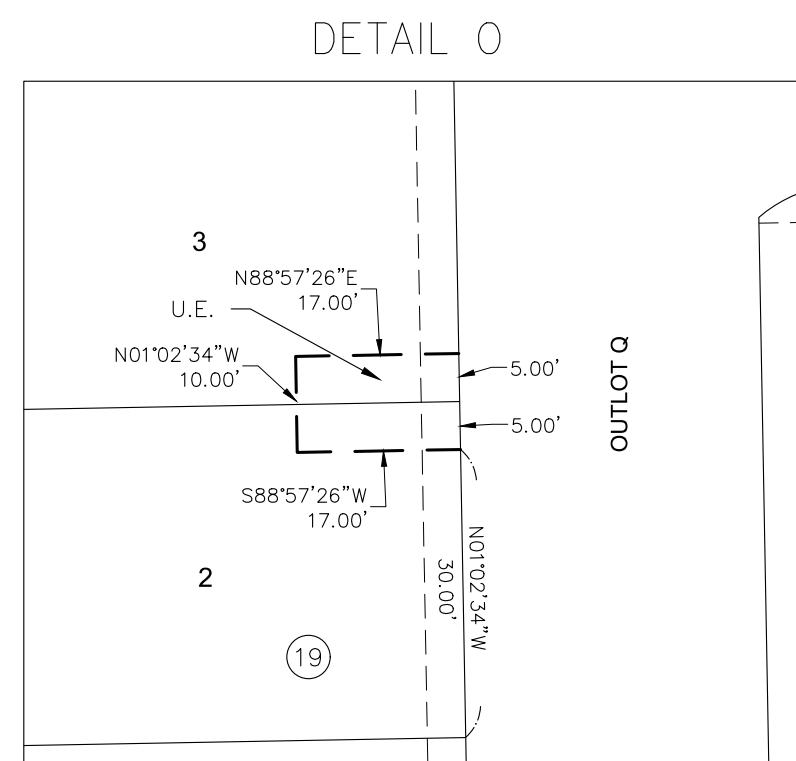

SCALE: 1" = 20'

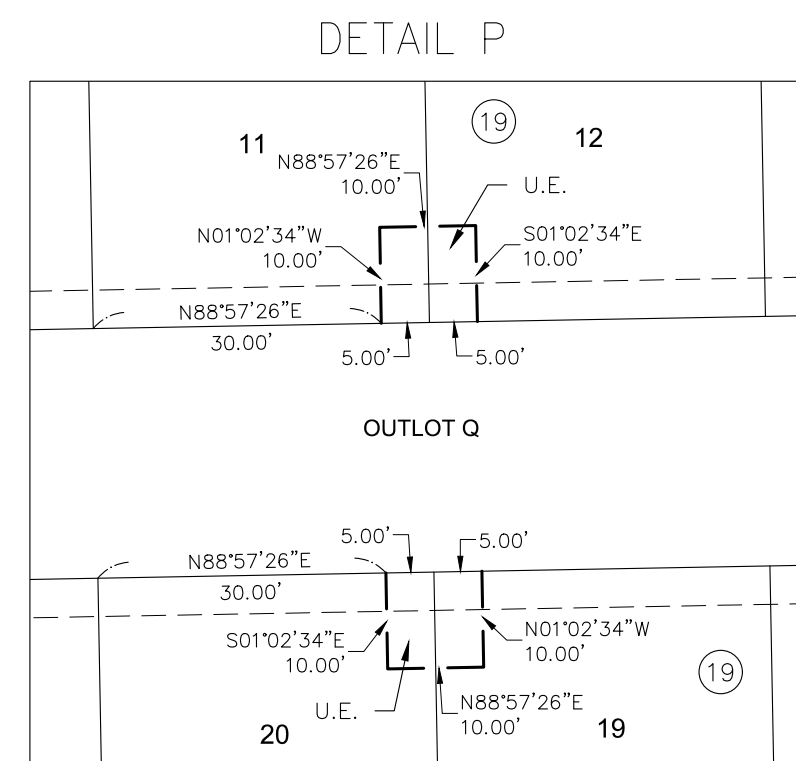

SCALE: 1" = 20'

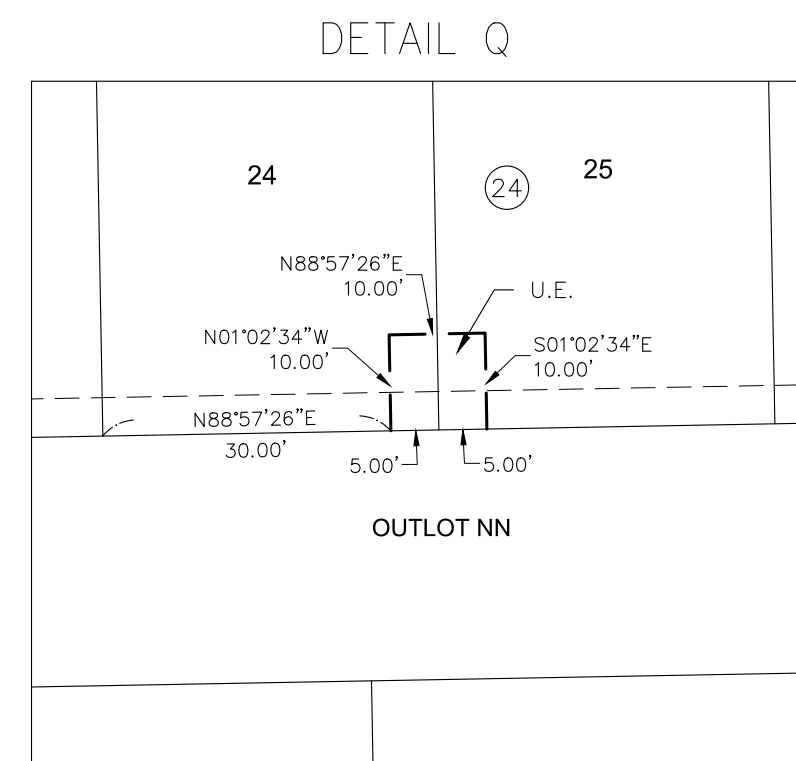

SCALE: 1" = 20'

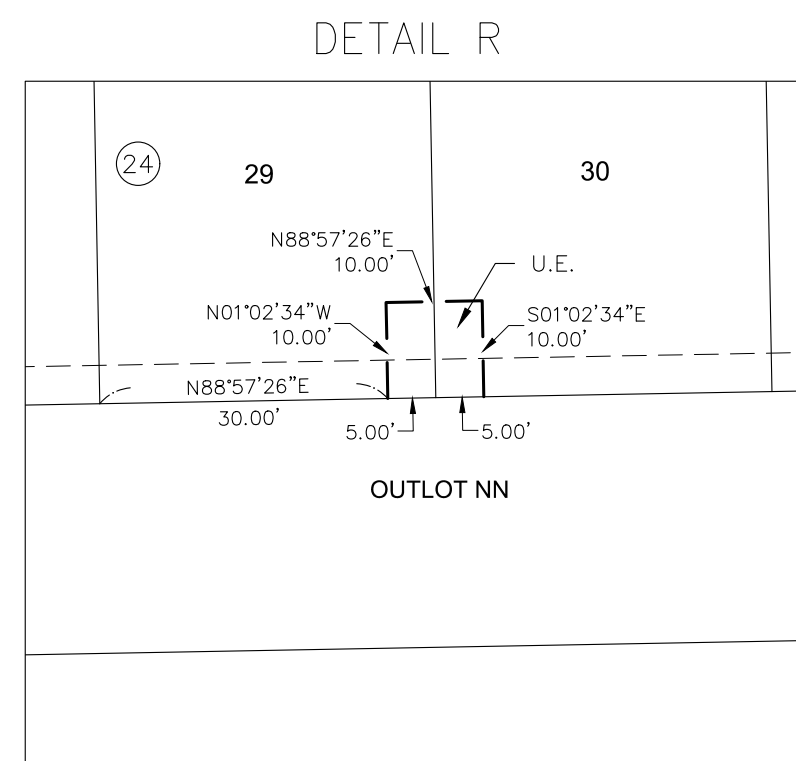

SCALE: 1" = 20'

PROJECT: SUPERIOR RESIDENTIAL CAD SURVEY FINAL PLAT SUPERIOR - PLAT DETAILS DWG. MICHAEL P. 11/19

ENGINEER/SURVEYOR

CIVIL CONSULTANTS
10333 E. Dry Creek Rd., Suite 240
Englewood, CO 80112
Tel: (720) 482-9526 / Fax: (720) 482-9546

